

# Motor Protection Concepts and Type 2 Co-ordination Charts



\*\*\* **UPDATED** \*\*\*  
July 2022

## ABOUT US



Switchgear Factory, Navi Mumbai



Switchgear Factory, Ahmednagar



Switchgear Factory, Vadodara

L&T Electrical & Automation (E&A) is a market leader for electrical distribution, monitoring and control solutions in the low voltage category.

Popular among customers as L&T Switchgear, E&A offers a wide range of low and medium voltage switchgear, motor starters, electrical systems, industrial automation, building electrical solutions, energy management solutions, electrical modernization solutions and metering solutions. Its products and solutions cater to key sectors of economy like industries, utilities, infrastructure, building and agriculture.

E&A's manufacturing operations at Navi Mumbai, Ahmednagar, Vadodara, Coimbatore and Mysuru in India adhere to global practices of excellence and receive support from well-equipped in-house design and development centres as well as tooling facilities that contribute to precision in manufacturing.

# Knowledge Portal

One Place for all L&T Electrical & Automation Technical Documents



## Download "Knowledge Portal" for the following benefits:

- ▶ Easy and quick access for
  - Catalogues
  - Technical articles
  - Product Manuals
  - Price lists
  - Dimensional drawings
  - Installation videos and many others
- ▶ Instant access to all new releases of documents
- ▶ Only access the latest - No more confusions over which is the latest
- ▶ Automatic deletion of out-dated content
- ▶ No need to pile-up printed copies of catalogues/notes
- ▶ Offline access – No need to be online always

Download Knowledge Portal from <http://www.LNTEBG.com/KP> and stay up-to-date!

[For Windows based Laptop/desktop]

For other software from us, please turn the page

### **Customer Interaction Center (CIC)**

BSNL / MTNL (toll free): 1800 233 5858 Reliance (toll free): 1800 200 5858

Tel: 022 6774 5858 Fax: 022 6774 5859 Email: [cic@lntebg.com](mailto:cic@lntebg.com) Web: [www.lntebg.com](http://www.lntebg.com)

# Pricelist on your Fingertips

One container app for all  
L&T Electrical & Automation (E&A) Mobile Applications

- Save time:** Instant access to all MRPs on the go
- Save Effort:** Access to all our Apps in one place
- Save Space:** No need for hard copies



**Download L&T Electrical & Automation ESP BizWhiz From Google Play Store/Apple App Store**

## Optimise Power Quality Solutions with etaPRO v3.0

Now with AHF selection tool

- Save time:** Instantly select the right capacitor-reactor and switchgear combo
- Save money:** Calculate monthly payback
- Save effort:** Directly export bills of materials to MS Excel
- Discover more:** Learn improved techniques on PQS

**Download from [www.LNTEBG.com/etaPRO](http://www.LNTEBG.com/etaPRO)**

(For Windows based Laptop / desktop)



## Download all E&A's digital technical documents with Knowledge Portal

- Product catalogues • User manuals • Application notes
- Drawings • Technical notes • Installation videos

- Save time:** Instant access to the latest updates
- Save space:** No need to print and maintain hard copies

**[www.Lntebg.com/KP](http://www.Lntebg.com/KP)**



# Motor Control solutions



L&T Electrical & Automation (E&A) – India's largest manufacturer of low-voltage switchgear has always been in the forefront of motor control solutions.

In the last few years, motor control solutions have seen a paradigm shift. With constantly evolving Industry requirements and technology advancement, there is a great demand for intelligent and automated solutions. Similarly, there is a greater demand for fuseless systems over fused systems.

With our deep understanding of customer needs, we make sure that each and every need is met by our extensive range of switchgear products.

Motor feeders are generally classified into two types: Fuse and Fuseless based on the type of short circuit protection devices used. Fuse systems incorporate fuses while fuseless systems have either molded case circuit breakers (MCCBs) or Motor Protection circuit breakers (MPCBs).

The MCCBs are available for various current ratings and KA levels depending on the application. This offers you the flexibility of making the most apt selection as per your application. We have DM and d sine-M range of MCCBs which are exclusively designed for motor protection.

MOG motor protection circuit breakers offer the advantage of having both overload and short circuit protection in a single compact unit. This solution is cost effective and ensures savings in panel space.

The other major parts of any motor feeder are the contactors and relays. Contactors are the predominant switching devices with a high mechanical and electrical life. Overload relays offer protection against overload and single phasing and can be directly mounted onto the contactors. This makes the motor feeder extremely compact and modular.

We offer an extensive range of MO and MNX contactors complemented by RTO and MN relays respectively.

E&A also offers range of microcontroller based Motor protection relays to cater to various customer requirements. REO – Electronic overload relay with inbuilt CT's provides Overload, Earth fault, Locked rotor, Phase failure & phase unbalance protection. Our communicable Motor protection and control relay - MCOMP offers complete solution for Intelligent MCC's

Thus, E&A's extensive range of switchgear products caters to all your motor protection & control needs.



The following sections take you through concepts of motor starting and motor protection solutions. In the further sections, Type-2 coordination selection charts are provided for making the right component selections. The main topics discussed in the following sections are:

- Types of motor starting
- Selection of Protection Devices for Motor Feeders and Type 2 Co-ordination
- Co-ordination for Energy Efficient Motors
- Co-ordination of Contactors & Overload Relays with MCBs
- Type 2 selection charts

# Types of Motor Starting



The most common method of motor starting is either Direct On Line (DOL) or Star - Delta. DOL starting is simple direct switching of a motor, however it leads to a high starting current. Star - Delta method is adopted in the motor feeders where high starting current is not acceptable.

## DOL Starting

While DOL starting method is simple & most commonly used, care has to be taken while selecting the SCPD & relay. The possibility of high current peak & higher starting time during starting must be kept in mind. This is especially important while choosing MCCB & MPCB as SCPD as these device can sense current peaks & may trip. Hence it is recommended to select MCCB & MPCB with magnetic threshold of at least 12 times of motor full load current for all standard motors & at least 14 times of full load current for high efficiency motors.

## Star - Delta Starting

Star Delta starting method is popularly used to reduce the motor starting current. For Star-Delta motor feeders, the motor winding is connected in star. When it reaches a certain speed the motor winding connection is changed to delta.

## Star Delta Starting can be of Two Types

### Open Transition

Open transition star delta starting is preferred in majority of the motor starting applications. In open transition starting there is a momentary loss of supply to the motor when the changeover from star to delta takes place. When the ON button is pressed, the star and main contactors get picked and the motor is connected in star configuration. As a result a reduced voltage ( $V_L/\sqrt{3}$ ) is applied across motor windings. The motor continues to run in star connection for a period set in the star delta timer. After the time delay, star contactor drops off and delta contactor picks up causing the motor to get connected in delta. There is a pause time of the order 50 - 80 msec configured in every star delta timer. This is to ensure that delta contactor picks up only after star contactor has fully dropped to prevent the eventuality of a short circuit. When this changeover takes place, the motor sees a zero voltage across its terminals momentarily. During this time the rotating magnetic field across the stator reduces to zero. However the rotor is still spinning and has a magnetic field. This spinning action of the rotor causes a voltage to be induced in the stator determined by the speed of the rotor. This induced voltage across the stator is called the back EMF. When the motor is now connected in delta full line voltage appears across its terminals. The difference between the back emf and supply voltage causes a high transient current and corresponding high transient torque. Hence the motor experiences a jerk. The magnitude of the transient current depends on the phase relationship between the back EMF and supply voltage at the time of closure. This current peak may reach a value of about  $18I_n$  and a corresponding mechanical jerk, which can be damaging to some critical processes. To avoid this closed transition starting is used in such cases.

## Close Transition

Close transition starting is used to reduce the high switching transients developed in the formerly discussed open transition starting and thus avoiding mechanical jerks. In close transition starter, a smooth changeover from star to delta takes place without the temporary loss of supply to motor. Thus even during the changeover from star to delta the motor continues to remain connected to the supply thus eliminating the switching transients. This is brought about by employing a fourth contactor along with a set of resistors. When the star contactor is opened, supply is maintained through the motor terminals via the resistors. The resistors are then shorted by the delta contactor when it closes. Let us understand the working with the help of a circuit diagram.

Advantages and Disadvantages of Closed Transition starters:

### Advantages

- 1) Operation is simple and rugged
- 2) Transition Peak is reduced to 1.5 times full load current instead of 18 times in open transition
- 3) The sudden jerk the motor experiences in open transition, while closing the delta contactor is avoided

### Disadvantages

- 1) More expensive
- 2) Starter can be bulkier

Thus open transition method is used for most of the applications owing to lesser cost. Closed transition starting is preferred only in critical applications where a smooth changeover from star to delta is required without the momentary jerk.

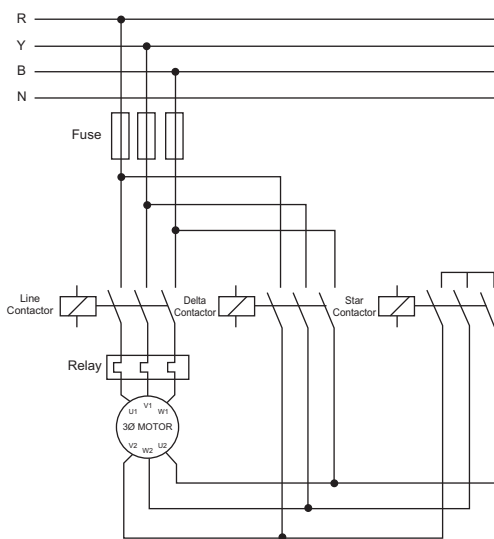

**Circuit diagram of a typical open transition Star Delta (SD) motor starter feeder.**

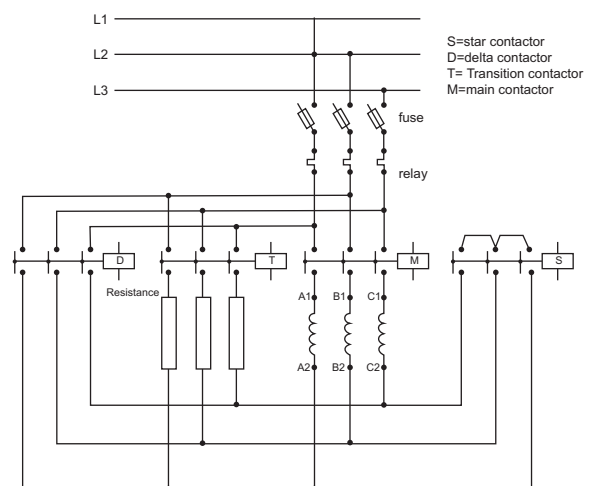

**Circuit diagram of a typical close transition Star Delta (SD) motor starter feeder.**



# Selection of Protection Devices for Motor Feeder

## Introduction

Motors are the backbone of any industry and their use is also rapidly increasing in commercial establishments. Protection of motor, hence becomes important to keep these processes functioning safely and without any interruption.

The main purpose of motor protection system is to prevent excessive temperature built up in the windings because of over-current or short-circuit current. Following are the reasons for over-current:

- Overloading
- Single Phasing
- Voltage Imbalance

Studies show that about 40% of the motor failures are due to electrical faults like over load, single phasing & short circuit. Hence it is extremely important to select effective motor protection devices to safeguard motors against any of the above faults, that will make motor windings to exceed safe working temperature. More importantly, the protection devices should be co-ordinated.

## Thermal Overload Relay

Thermal overload relay should protect the motor against single phasing and overloading or locked rotor condition. At the same time, it should permit starting of the motor. In other words, it should withstand starting current for a duration equal to the starting time of the motor.

IEC 60947-4-1 and IS/IEC 60947-4-1 has facilitated selection of a relay by defining a 'Trip Class'.

Trip classes are mentioned in table 1. A relay of appropriate trip class can be selected by comparing 'locked rotor current withstand time' for the motor with maximum trip time. For example, for a motor with 'locked rotor current withstand time' of 15 seconds, the relay should have trip time less than 15 seconds at a current equal to locked rotor current. Hence, with reference to Table 1, a relay of 10A trip class will provide adequate protection.

**Table 1: Trip Class for Thermal Overload Relays**

Trip Class	Tripping Time, $T_p$ , Seconds*
10A	$2 < T_p \leq 10$
10	$4 < T_p \leq 10$
20	$6 < T_p \leq 20$
30	$9 < T_p \leq 30$

\* at 7.2 times the relay setting.

New generation of thermal overload relays incorporating “double slide mechanism” provide excellent protection against phase unbalance and phase failures even when motor is not running at full load. These relays don’t see single phasing as overloading of others phases due to the double slide mechanism and hence work faster and effectively. Unbalanced voltages result in high unequal currents in stator windings and consequently higher temperature rise. Though balanced voltages are preferred, in some applications, voltage unbalance is unavoidable and some derating might be necessary. Where a motor is derated, selection of overload relay should take into account the derating factor.

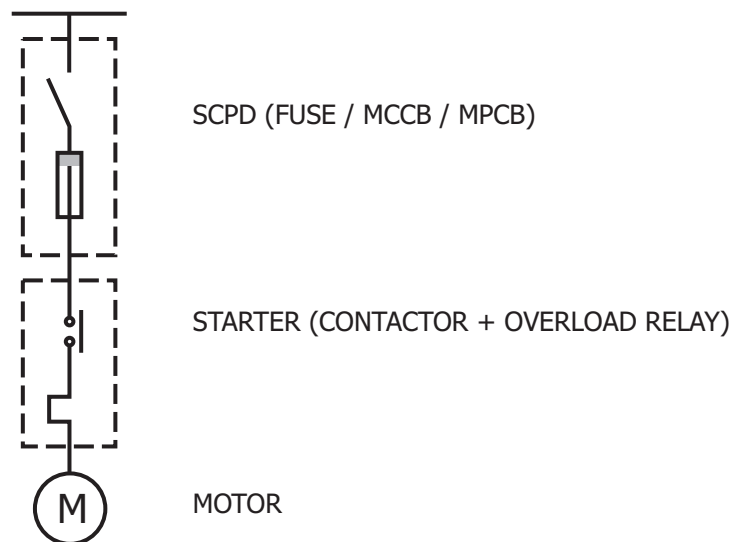

**Fig. 1**

**Single line diagram of a typical Direct-on-line (DOL) motor starter feeder.**

### Short Circuit Protective Devices (SCPD)

The current trends in Motor feeder protection are:

- Fused protection with S-D-F
- Fuseless protection with MCCB or MPCB

While these devices are generally fast in clearing S.C. faults, they do take finite time to operate. By the time SCPD interrupts short circuit current, certain amount of fault energy passes through the protected circuit. All the downstream devices and cables in the protected circuit are subjected to stresses corresponding to this energy.

The two important parameters which indicate the extent of stresses generated by short circuits are 'I<sup>2</sup>t let through' and 'cut-off current'. These are explained in Fig. 3. 'I<sup>2</sup>t let through' signifies thermal stresses. 'Cut-off current (I<sub>c</sub>)' is indicative of electro-dynamic stresses that various devices and links / cables will have to withstand. Lower 'I<sup>2</sup>t let through' and 'cut-off current' indicate a more efficient SCPD and hence better short circuit protection.

- S-D-F, which incorporates H.R.C fuses, is the most efficient and popular in the industry. S-D-F, like conventional fuse-switch units, is capable of switching and protecting electrical circuits. In addition they have minimum let through energy & cut off current offering the most economical protection package. These are also suitable for isolating down stream equipment

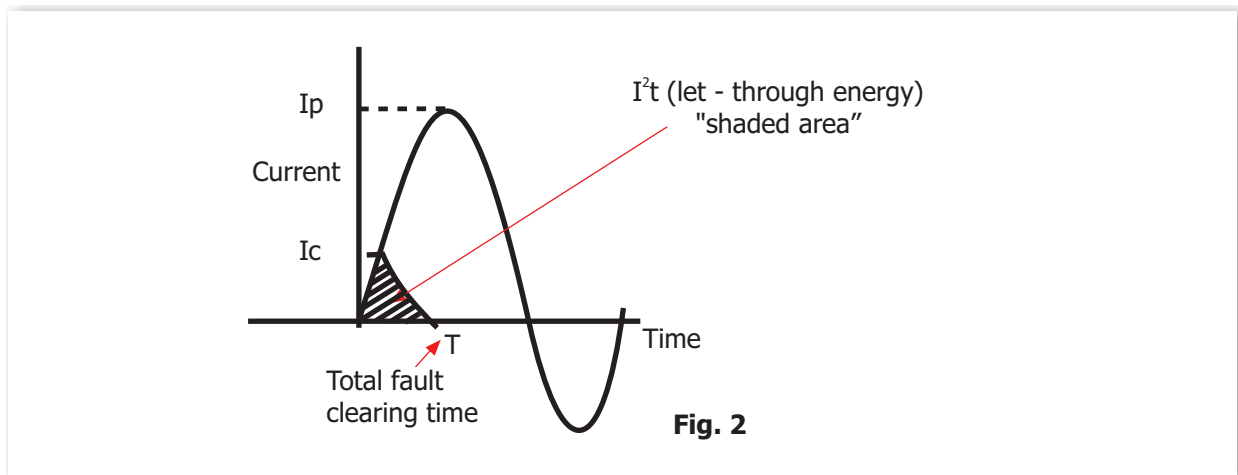

- MCCB was primarily used for protection of distribution circuits. However, with the development of current limiting MCCBs, it has become possible to employ MCCBs in motor feeders also. With the availability of various accessories, MCCB as SCPD offers several advantages like low downtime & enhanced flexibility. However the let through energy & cut off current of MCCB is still higher compared to H.R.C. Fuses
- Motor protection circuit breakers (MPCBs) combine short circuit and overload protection in a single compact unit. MPCB can be used in two ways. Firstly, it can be used for directly switching of a motor. This is very cost effective. However downside is that electrical life of MPCB is limited compared to that of a contactor. Moreover, a separate undervoltage protection is required. Alternately, MPCB can also be used along with a contactor. Since, MPCB combines thermal as well as short circuit protection, it will trip and interrupt even small overloads (which otherwise could be interrupted by a relay) and contactor will be used for switching the load

## Co-ordination of Thermal Overload Relay & SCPD

### What is Co-ordination?

Co-ordination means matching the characteristics of SCPD and down stream equipment to ensure that the let-through energy and peak cut-off current do not rise above the levels that the feeder can withstand.

IEC / IS / EN specifications require that thermal overload relays and SCPD are co-ordinated to ensure that they operate satisfactorily under all load and fault conditions. Following two aspects need to be considered to achieve proper co-ordination:

- Discrimination between thermal overload relay and SCPD
- Adequacy of short circuit protection

### Discrimination

To understand various considerations for proper co-ordination, time-current characteristics of thermal overload relay, H.R.C. fuse, MCCB with only instantaneous release and MPCB are superimposed on motor starting characteristics in Fig. 3b, 4b and 5b. Intersection of characteristics of thermal overload relay and Fuse / MCCB / MPCB is termed as 'cross-over point' and corresponding current as 'cross-over current'  $I_{co}$ .

Following points are to be ensured while selecting components to have properly co-ordinated motor protection:

- Contactor rating (AC-3) should be more than or equal to motor full load current (if application is AC-3 duty)
- Thermal overload relay of appropriate 'Trip Class' is selected. Time current characteristics of the relay should remain above motor starting characteristics as shown in Fig. 3b and 4b

- For fault currents lower than 'cross-over current  $I_{co}$ ', relay will respond faster than SCPD and hence contactor will interrupt the fault current. Fault currents higher than  $I_{co}$  will be interrupted by SCPD. Hence, rating of contactor is so chosen that  $I_{co}$  is less than rated breaking capacity of the contactor
- Relay and contactor should be able to withstand  $I_{co}$  for a duration equal to trip time of the relay. IEC / IS / EN standards require that the contactor should be able to withstand at least current equal to 8 times AC-3 rating (6 times for ratings higher than 630A) for 10 seconds
- While using MCCB or MPCB, attention needs to be given to motor peak starting current. To avoid nuisance tripping of MCCB/MPCB during starting, instantaneous release shall be chosen as below:
  - For IE1 motors the starting current could be 6 times full load current so instantaneous release shall be chosen as 13 times the full load current of the motor
  - For IE2 motors the starting current could be 8 times full load current so instantaneous release shall be chosen as 14 times the full load current of the motor

The corresponding co-ordination curves for MCCB and MPCB are shown in Fig. 4b and 5b.

- Similarly, while using MCCB/MPCB as a SCPD for Star-Delta starter, consideration needs to be given to peak current associated with change over from Star to Delta. Instantaneous release of MPCB is normally set at 13 times the rating. Hence, possibility of nuisance tripping needs to be considered while using MPCB for protection for Star Delta starter feeder

## Type 1 and Type 2 Co-ordination in Motor Feeders

Standards like IEC: 60947-4-1 and IS/IEC: 60947-4-1 specify motor protection requirements for selection of switching & protection device for motor feeders. Since there are more than one switching & protection device, it is necessary to co-ordinate the selection of components for a motor feeder. This is to be done keeping in mind the capabilities of the individual components. Such a co-ordinated selection will firstly, ensure safety to the user & secondly, provide the expected performance & life of the feeder components.

Selection of components involves co-ordination of characteristics of various devices i.e. of the overload relay & of short circuit protection device of the motor feeder.

As per the standard two types of co-ordination are permissible, Type "1" and Type "2".

**Type "1"** co-ordination requires that under short-circuit conditions, the contactor or the starter shall cause no danger to persons or installation. The motor feeder may not be suitable for further service without repair and replacement of parts.

**Type "2"** co-ordination requires that under short-circuit conditions, the contactor or the starter shall cause no danger to persons or installation and shall be suitable for further use. However contact welding is recognized. Also the time-current characteristics of the over load protection device should not change. This in other words means safety, low down time and continued protection.

Recommended combination needs to be proven through short-circuit tests at:

- Prospective current "r"
- Conditional short-circuit current "q"

Test at Prospective current "r" is done to verify the performance under fault conditions practically possible at the motor feeder end. These faults are normally associated with the motor and the associated feeder. Prospective current "r" is specified according to the rated operational current (Ie, AC-3) of the feeder. If the motor feeder is not specified according to utilization category AC-3, the prospective current "r" shall correspond to the highest rated operational current for any utilization category claimed by the manufacturer. The values are mentioned below:

**Table 2: Short Circuit Performance: 'r' Current**

Rated operational current Ie (AC-3) A	Prospective current "r" kA
0 Ie ≤ 16	1
16 < Ie ≤ 63	3
63 < Ie ≤ 125	5
125 < Ie ≤ 315	10
315 < Ie ≤ 630	18
630 < Ie ≤ 1000	30
1000 < Ie ≤ 1600	42
1600 < Ie	Subjected to agreement between manufacturer and user

Test at Conditional short-circuit current Iq is carried out to verify the performance under system level faults. Iq is declared by the manufacturer. This is the maximum fault current that the feeder can withstand. Generally the declared value of Iq is 50 kA.

**Problems due to an improperly co-ordinated system**

An improperly co-ordinated system can lead to:

- High electro-dynamic force (magnetic force proportional to I<sub>peak</sub>)
- Nuisance tripping of / operation of SCPD under small overloads leading to reduced life of SCPD
- Nuisance tripping of SCPD during motor starting (DOL)
- Nuisance tripping of SCPD during transient conditions like open transition starting of a Star Delta starter

### Typical DOL Motor Feeder with S-D-F

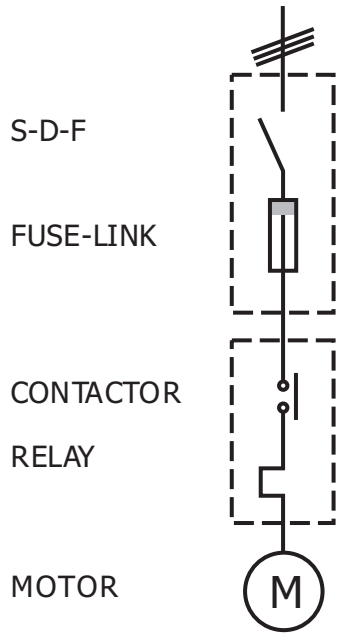

Fig. 3a

### Co-ordination with S-D-F

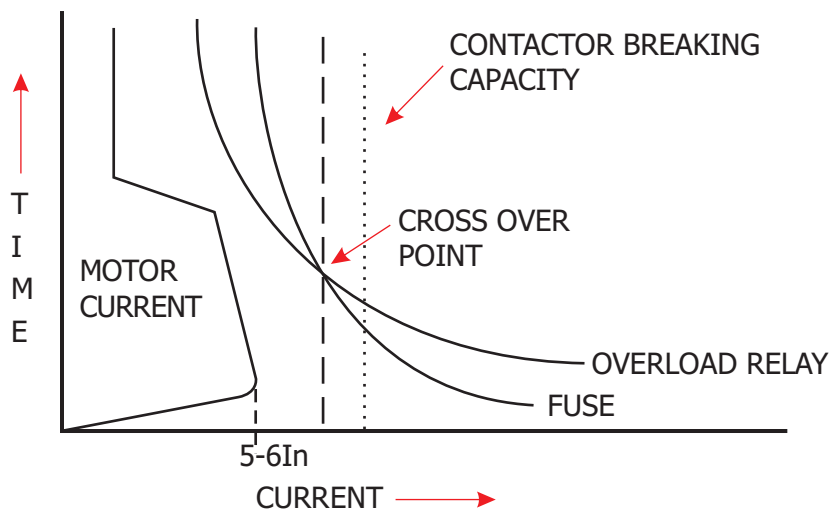

Fig. 3b

### Typical DOL Motor Feeder with MCCB

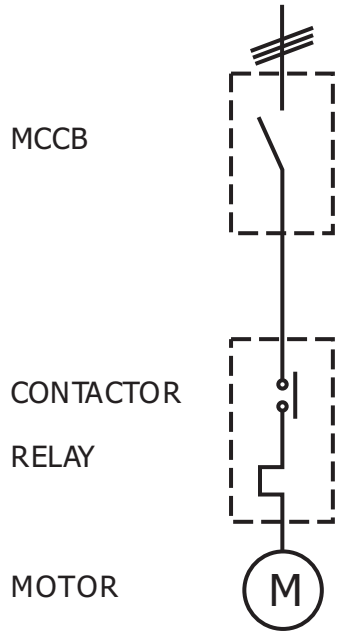

Fig. 4a

### Co-ordination with MCCB

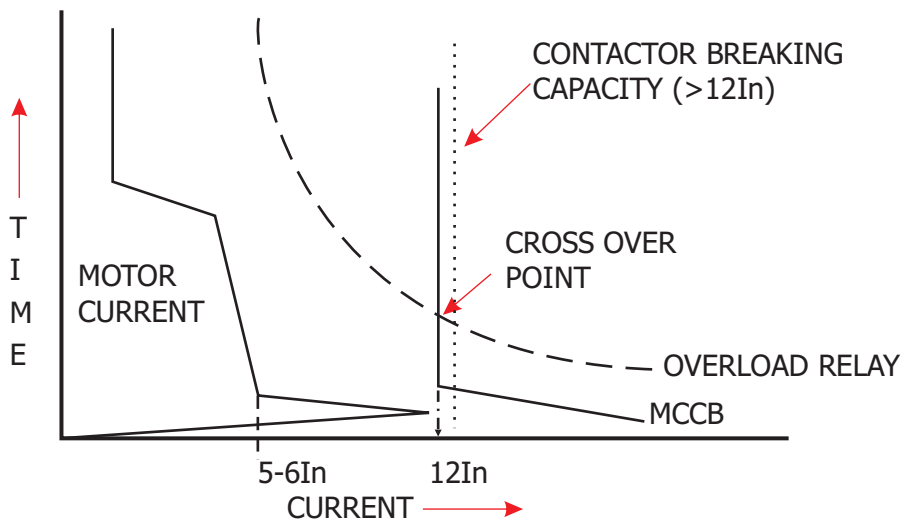

Fig. 4b

### Typical DOL Motor Feeder with MPCB

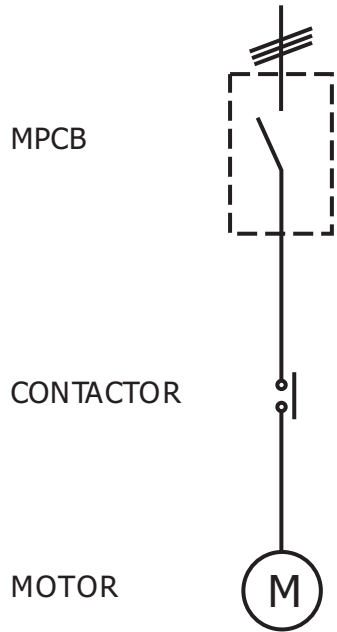

Fig. 5a

### Co-ordination with MPCB

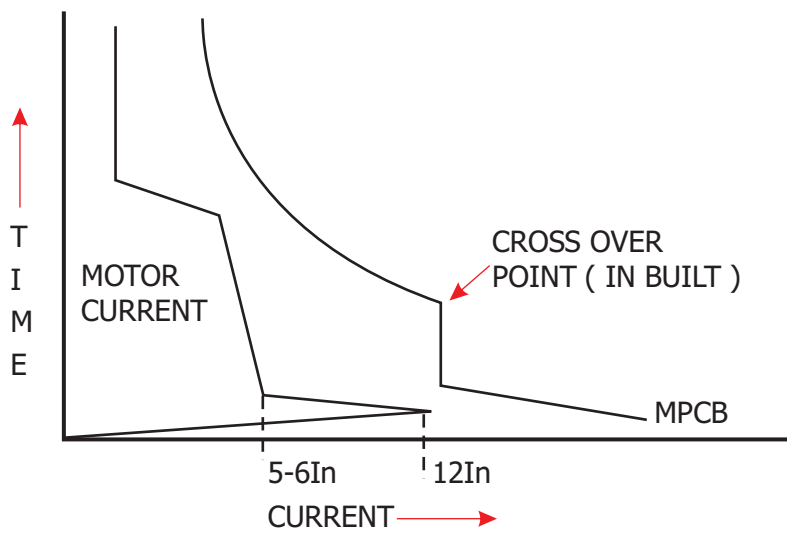

Fig. 5b



# Co-ordination for Long Starting Time Application

This note explains contactor selection for motors with long starting time. The note has been divided into three parts for easy understanding of the concepts involved. They are as follows:

1. Understanding Motor Inrush Current
2. Long Starting Time Applications
3. Contactor selection for motors with long starting time

## Understanding Motor Inrush Current (Stator current)

A motor generally drives a load through some transmission system. During start, the motor draws a high starting current or inrush current.

This current is about 6-8 times the motor rated current and can cause a significant voltage drop. This voltage fluctuation affects other devices connected to the same supply. Hence several other strategies are employed for starting motors to reduce its starting current; the most commonly employed being the Star-Delta starting. The starting value of the current is independent of the load attached; however it must be sufficient to overcome the inertia of the motor load system. However, inertia of the load impacts the starting time of the motor as explained in the next part. As the motor accelerates and nears its rated speed, the current gradually reduces and settles down to a value equal to motor rated current or less depending on the actual load connected. The typical torque-speed characteristics of an induction motor are as given below:

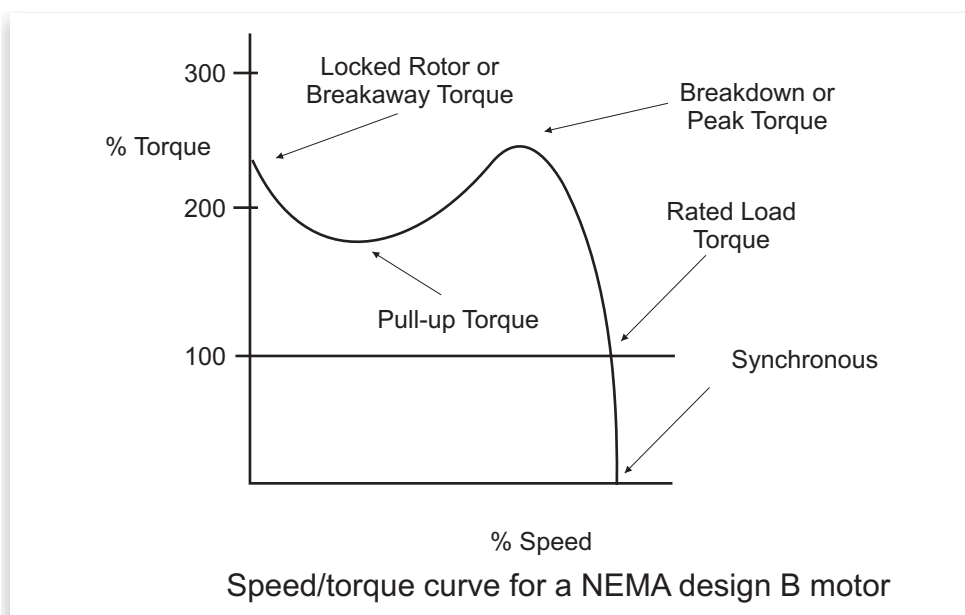

## Long Starting Time Applications

The total time from rest till the motor draws its rated current is called the starting time. The starting time of the motor is a function of the load inertia, load speed and the starting torque developed by the motor. A high inertia load requires an extended time to reach full speed and hence the motor also draws high starting current for a long time. The motor starting time is specified by the manufacturer in the motor data sheet. Since motor starting time is also a function of applied voltage it differs for different starting methods. For example starting time of the motor with Direct-Online starting would be different than with Star-Delta starting.

The starting line current in Star Delta configuration is one third of the starting current of the same motor in DOL configuration. However applied voltage and therefore starting torque also reduces, leading to higher starting time.

## Long Starting Time Applications are Generally those Applications in which the Motor Starting Time is around 40 to 120 secs

Typical applications involving motors with a high starting time are:

- Induced Draft Fans (ID Fans)
- Forced Draft Fans (FD Fans)

ID and FD fans have a high inertia and hence motors required to drive them will have a long starting time. As a result the motor will draw high inrush current for an extended period of time.



The high inrush current drawn by the motor at start is carried by the contactors that are used for switching. Since, this current flows for an extended period of time, the contactor needs to be selected judiciously. Guidelines for selection of contactor rating is as follows:

## Contactor Selection for Motors with Long Starting Time

Contactors are selected based on their overload current withstand capability. Overload withstand capability is defined in IEC 60947-4-1 as given below:

Rated Operational Current $I_e(AC3)$	Test Current	Duration of Test
$\leq 630$ A	$8 \times I_e \text{ max/AC-3}$	10 sec
$> 630$ A	$6 \times I_e \text{ max/AC-3}^*$	10 sec

It means that a contactor with rated operational current equal to or less than 630A can withstand 8 times its rated AC3 operational current for a period of 10 seconds. This rating is also called as the 10 sec rating of the contactors.

For Example:

Let Rated operational current (AC3 Utilization category) of contactor = 400A

Then the maximum current it can carry for a period of 10 sec =  $8 \times I_e = 3200A$

Now let us look at an example, how to arrive at minimum AC3 Ratings of the Star, Main and Delta contactors.

## Motor Specifications

Motor kW Rating: 160 kW

Motor Full Load Line Current: 304A

Motor Starting time in Star-Delta: 85 sec

## Solution

Delta contactor can be directly selected as per type 2 chart specified by the contactor manufacturer. This is because delta contactor is connected only when the motor has reached near its rated speed and motor current has reduced to its full load value.

**For selection of Star contactor and Main contactor, the withstand current must be taken into consideration.**

A general schematic of Star-Delta starter is shown below:

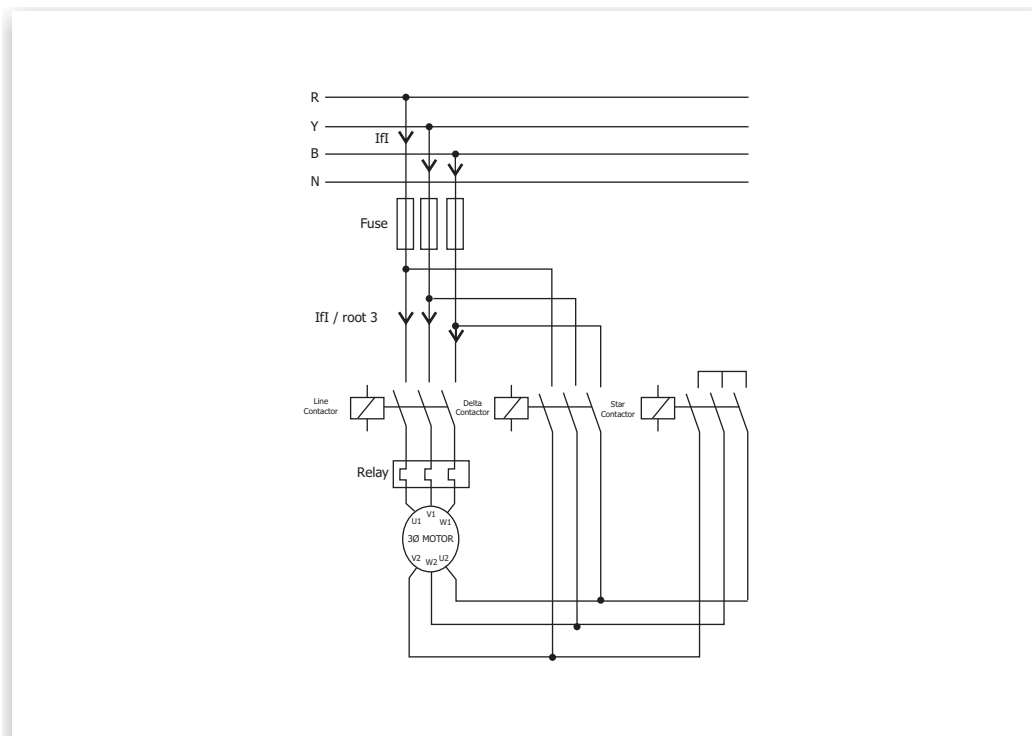

Starting current in a normal delta motor with DOL starting is around 6 - 8 times the motor full load current. However in Star-Delta starter motor starting current in star is reduced to 1/3 of this value. Typically starting current when using Star-Delta starting method is around 2.2 times motor full load current.

Starting current ( $I_s$ ) = 2.2 x motor full load current = 2.2 x 304 = 669A

Starting time ( $T_s$ ) = 85 sec

Therefore,  $(I_s)^2 \times (T_s) = 669 \times 669 \times 85 \dots\dots\dots(A)$

Now, Value (A) must be less than the contactor withstand capacity. i.e.

Based on IEC 60947-4-1,

Contactor Withstand Capacity =  $(8 I_e (AC3))^2 \times 10 \dots\dots\dots(B)$

It is required that,  $B > A$

$$I_e (AC3) > \left( \sqrt{\frac{A}{10}} \div 8 \right)$$

Solving the above equation:  $I_e(AC3) \geq 243.8$

The contactor must be selected such that its rated AC-3 current  $I_e$  satisfies the above condition.

Therefore in this case MNX 250 can be selected for Star & Main Contactor.

In case of a 160 kW motor with normal starting time (<10 sec) the selection of contactors according to type 2 charts is:

Star Contactor: MNX 140

Main and Delta Contactor: MNX 185

However for the same 160 kW motor with long starting time (85 sec in this case) the contactor selection is:

Star Contactor: MNX 250  
 Main Contactor: MNX 250  
 Delta Contactor: MNX 185 } ..... (C)

This gives us the minimum rating of contactor required to withstand the starting current.

We also need to evaluate the fuse rating for long starting time because the let through energy will increase. For a start time of 6-7 sec for the given motor rating (160KW) in star delta feeder, the fuse rating is 315A as per type 2 coordination. For long starting time, fuse rating shall be chosen by referring by Time-current characteristic of fuse as shown below. The curve of the fuse shall lie above the crossing point of current and time. In this case the fuse rating comes out to be 315A.

## HRC Fuse-links Type HN

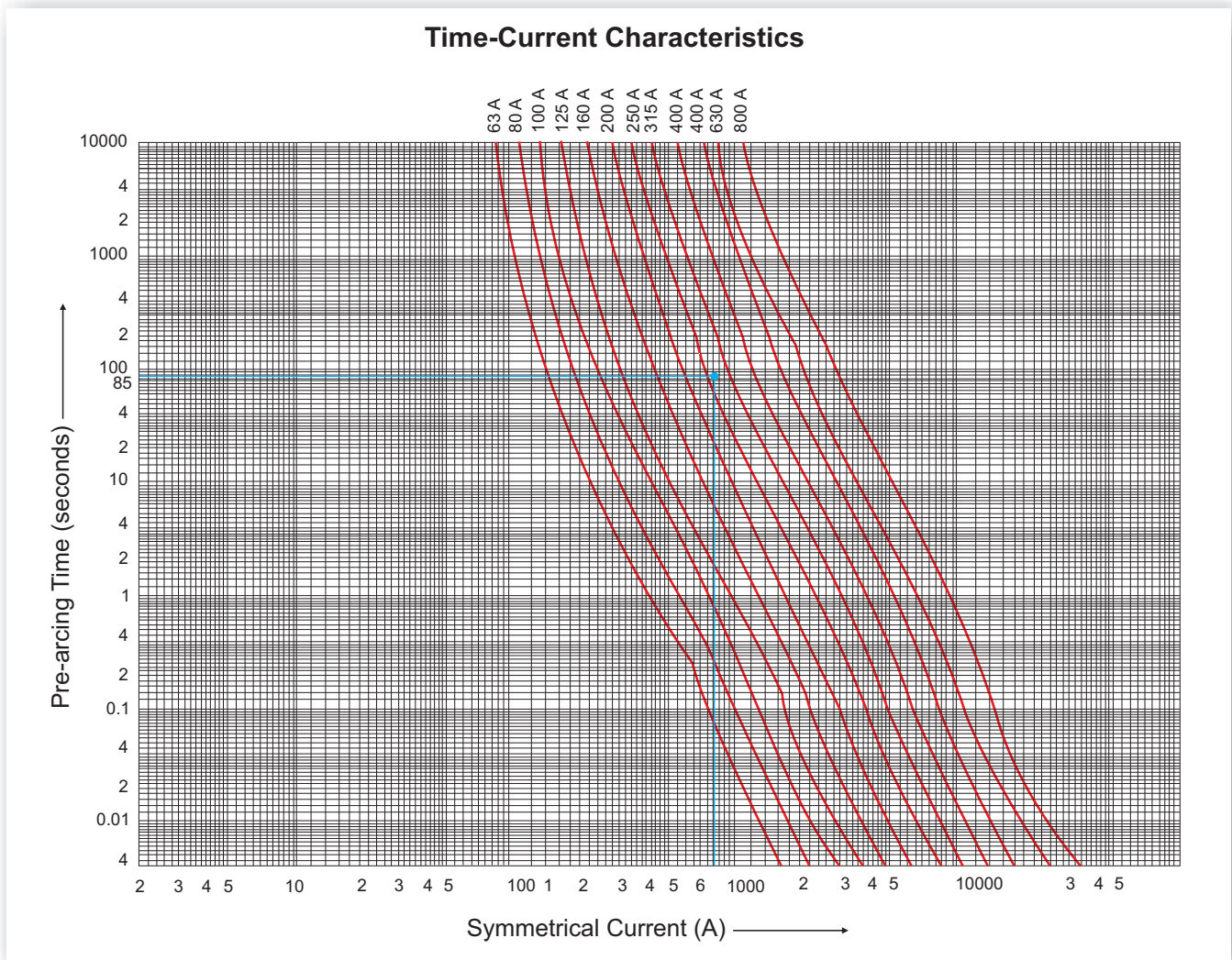

The contactor suitable to withstand the let through energy of 315A fuse is:

Star: MNX 140

Delta and Main: MNX 225

Compare above contactor sizes with the contactor size derived in point no. (C) and select the higher contactor rating.

Hence in case of 160KW motor, 85 sec starting time with star delta starting method, the selection of contactor and fuse will be:

Main Contactor: MNX 250

Star Contactor: MNX 250

Delta contactor: MNX 225

Fuse: 315A

Finally note that the Overload relay should be bypassed for this starting time, else it will trip during starting. Other alternative is to go with numerical motor protection relay where starting characteristics are programmable as required.

# Co-ordination for Energy Efficient Motors

## Energy Efficient Motors and Corresponding Modifications in Type '2' Chart

### Introduction

In industry, the electric motor applications consume about 30% to 40% of the generated electrical energy worldwide. According to the findings of the International Energy Agency (IEA) Motor Workshop, electric motors with improved efficiency in combination with frequency converters can save up to 7% of the total worldwide electrical energy. One quarter to one third of these savings come from the improved efficiency of motor.

As per motor regulation 640/2009, the European Economic Area (EEA) has banned IE1 (low efficiency) motors with effect from 16 June 2011. Only energy efficient (IE2 and IE3) motors are approved. However, the direct export of IE1 motors to countries outside the EEA is allowed by the act.

### Standard on motor efficiency

IEC 60034-30:2008 defines the new efficiency classes for motors. The efficiency levels defined in IEC 60034-30:2008 are based on test methods for determining losses and efficiency specified in IEC 60034-2-1: 2007

IEC 60034-30:2008 defines three IE (International Efficiency) classes of single-speed, three phase, 50Hz and 60 Hz, cage induction motors.

- IE1: Standard efficiency (Efficiency level based on EFF2)
- IE2: High efficiency (Efficiency level based on EFF1)
- IE3: Premium efficiency (Efficiency level with losses about 15% to 20% lower compare to IE2)

The standard also introduces IE4 (Super Premium Efficiency), a future level above IE3. However, the efficiency values for IE4 motors are not mentioned in the standard.

The standard IS 12615: 2011 is in line with standard IEC 60034-30: 2008. The change in nomenclature from EFF to IE is yet to be implemented by Indian manufacturer fully.

The standard IS 12615: 2011 has also mentioned the value of maximum full load current for all the efficiency classes. The efficiencies of the different classes as per IS12615: 2011 are mentioned in following table:

## Efficiency Comparison of 4 Pole Motors

Table 2 Values of Performance Characteristics of 4 Pole Energy Efficient Induction Motors  
(Class 1.2, 1.3, 4.3, 8, 14.1, 14.4 and 17.1)

**IS 12615 : 2011**

Sr. No.	Rated output	Frame Size	Full Load Speed	Full Load Current	Breakaway Torque in Terms of Full Load Torque	Breakaway Current in Terms of Full Load Current (Equal of Below)			Nominal Efficiency		
			Min	Max	Min	IE1	IE2	IE3	IE1	IE2	IE3
	Rev/min		A	Percent	Percent	Percent	Percent	Percent	Percent	Percent	Percent
(1)	(2)	(3)	(4)	(5)	(6)	(7)	(8)	(9)	(10)	(11)	(12)
1	0.37	71	1330	1.4	170	550	600	650	65.1	70.1	73.0
2	0.55	80	1340	1.7	170	550	600	650	69.1	75.1	78.0
3	0.75	80	1360	2.2	170	550	600	650	72.1	79.6	82.5
4	1.1	90S	1370	2.9	170	550	600	650	75.0	81.4	84.1
5	1.5	90L	1380	3.8	170	550	600	650	77.2	82.8	85.3
6	2.2	100L	1390	5.1	170	650	700	750	79.7	84.3	86.7
7	3.7	112M	1410	8.1	160	650	700	750	82.7	86.3	88.4
8	5.5	132S	1420	11.4	160	650	700	750	84.7	87.7	89.6
9	7.5	132M	1430	15.4	160	650	700	750	86.0	88.7	90.4
10	11.0	160M	1440	22.0	160	650	700	750	87.6	89.8	91.4
11	15.0	160L	1440	30.0	160	650	700	750	88.7	90.6	92.1
12	18.5	180M	1440	36.0	160	650	700	750	89.3	91.2	92.6
13	22.0	180L	1440	43.0	160	650	700	750	89.9	91.6	93.0
14	30.0	200L	1450	56.0	160	650	700	750	90.7	92.3	93.6
15	37.0	225S	1450	69.0	160	650	700	750	91.2	92.7	93.9
16	45.0	225M	1460	84.0	160	650	700	750	91.7	93.1	94.2
17	55.0	250M	1460	99.0	160	650	700	750	92.1	93.5	94.6
18	75.0	280S	1470	134.0	160	650	700	770	92.7	94.0	95.0
19	90.0	280M	1470	164.0	160	650	700	770	93.0	94.2	95.2
20	110.0	315S	1480	204.0	160	650	700	770	93.3	94.5	95.4
21	125.0	315M	1480	234.0	160	650	700	770	93.4	94.6	95.5
22	132.0	315M <sup>1)</sup>	1480	247.0	160	650	700	770	93.5	94.7	95.6
23	160.0	315L <sup>1)</sup>	1480	288.0	160	650	700	770	93.8	94.9	95.8
24	200.0	As per manufacturer catalogue	1480	348.0	160	650	700	770	94.0	95.1	96.0
25	250.0		1480	435.0	160	650	700	770	94.0	95.1	96.0
26	315.0		1480	548.0	160	650	700	770	94.0	95.1	96.0
27	355.0		1480	618.0	160	650	700	770	94.0	95.1	96.0
28	375.0		1480	653.0	160	650	700	770	94.0	95.1	96.0

### Notes:

- Output to frame size relation is maintained in accordance with IS 1231 for all motors except those marked as<sup>1)</sup>, where in the frame size indicated is 'preferred size'
- The performance value given in this table for 0.37kW and 0.55kW are under consideration and subject to review

## Graphical Comparison of the Efficiency Classes Motors

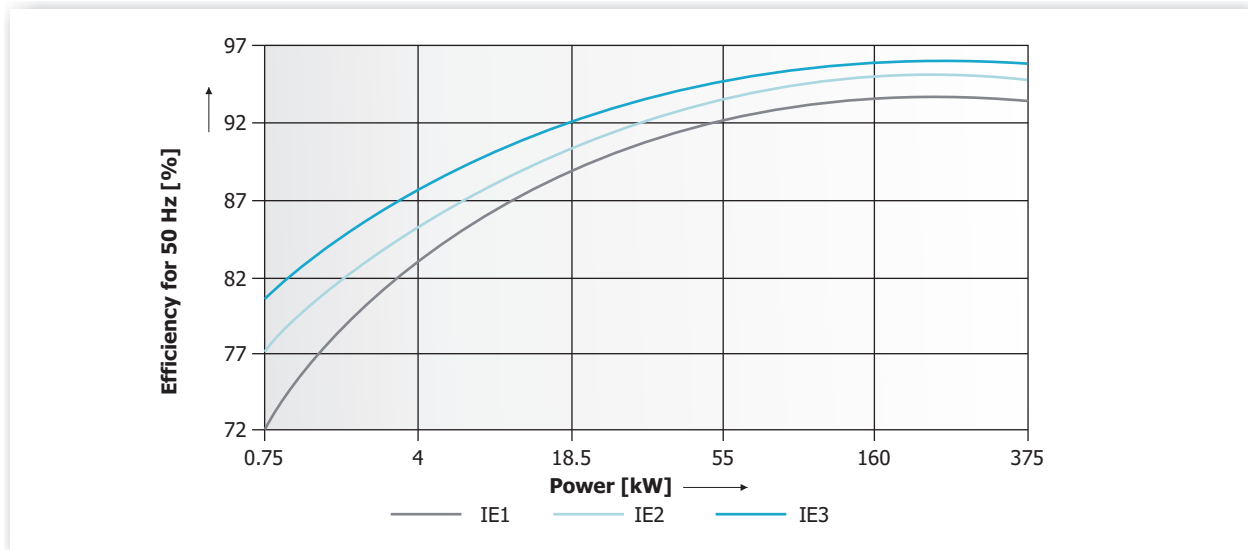

### Efficiency and Losses

The efficiency of a motor is defined as the ratio of output (mechanical) power to input (electrical) power. The efficiency of a motor is determined by the losses that can be reduced only by changes in motor design. Following are the typical motor losses:

1. Stator and Rotor  $I^2R$  Losses
2. Core Losses
3. Friction and Winding Losses
4. Additional Load Losses ( $P_{LL}$ ; It is that portion of losses in a machine not accounted for by the sum of friction and windage, stator  $I^2R$  loss, rotor  $I^2R$  loss and core loss)

Given below is the typical summary of losses distribution in a motor.

Type of Loss	% Contribution in Total Loss
Stator $I^2R$ Losses	37
Rotor $I^2R$ Losses	18
Core Losses	20
Friction and Windage Losses	09
Additional Load Losses	16

### Methods used to Achieve Higher Efficiencies

1. Reduction in Stator  $I^2R$  Losses: The Stator  $I^2R$  Loss is a function of stator current flowing through stator winding and the stator winding resistance. The resistance is given by following formula:

$$R = \frac{1.654qN^2L}{10^6C}$$

R = Resistance in ohm

q = No. of phases

N = Turns in series per phase

L = Mean length of turn in meter

C = Total cross section of copper in all the slots (in all phases) in  $m^2$



The suitable selection of copper conductor size will reduce the resistance of the stator winding.

2. Reduction in Core Losses: The Core Losses consist of hysteresis and eddy current losses in the stator. Eddy current losses are generated by circulating current within the core steel laminations. It is given by following formula:

$$W_c = \frac{K_e * f^2 * t^2 * B^2 \text{ max Watts per m}^3}{\rho}$$

$W_c$  = Eddy current loss

$K_e$  = Proportionality constant

$f$  = Frequency

$t$  = Thickness

$B_{\text{max}}$  = Maximum flux density in Weber per  $\text{m}^2$

$\rho$  = Resistivity

From the above formula, it is clear that the eddy current loss can be reduced by reducing the thickness of the core steel lamination suitably.

The hysteresis losses are a function of flux density which can be reduced by suitable increase in the core length of stator and rotor.

### Impact of Reduction in Losses on Motor Current

The increase in efficiency does not affect the full load current of the motor much. However, the starting current in case of high efficiency motor is more than that of standard motors.

The equations for full load current and starting currents are mentioned below:

$$\text{Stator current} = \left| \frac{V}{Z} \right|$$

$$Z = \frac{jX_m (R_2/S + jX_2)}{R_2/S + j(X_m + X_2)} + R_1 + jX_1$$

Where:  $R$  = Resistance,  $X$  = inductance,  $S$  = Slip of the motor,

suffix 1: stator, suffix 2: rotor

During starting period  $S = 1$

$$I_{\text{start}} = \left| \frac{V}{R_1 + jX_1} \right|$$

As mentioned above, in high efficiency motors  $R_1$  is reduced to reduce the stator loss and improve the efficiency. This increases the starting current of the energy efficient motors as compare to standard motors.

At full load  $S = 0$

$$I_{\text{fl}} = \frac{V}{Z_{\text{fl}} + R_1 + jX_1}$$

Where,

$$Z_{\text{fl}} = \frac{jX_m (R_2 + jX_2)}{R_2 + j(X_m + X_2)}$$

At full load speed,  $Z_{\text{fl}} \gg \gg \gg (R_1 + jX_1)$

Hence, the factor R1 being a smallest factor which contributes very less to the full load current, a small reduction in R1 does not affect the full load current much.

Most of the manufacturers claim the FLC and starting current of their motors. The motor efficiency values as claimed by ABB are mentioned in Annex 1.

As a result of the modifications to improve performance, the costs of energy-efficient motors are about 15% to 20% higher than those of standard motors. The higher cost is often being paid back rapidly in few years due to saving in operation of cost.

## Conclusion

1. As mentioned above, there is no change in FLC of the IE1, IE2 & IE3 motors. The relay range required for overload protection will remain unchanged in case of energy efficient (IE2) motors & (IE3) motors with respect to standard (IE1) motor
2. The starting current for energy efficient (IE2/IE3) motors is  $7-7.7I_n$  (As per IS12615: 2011). Where as the cross over point considered for existing back up fuse selection is between  $7.5I_n$  to  $10I_n$ . Hence there will be no change in type 2 chart with fuse protection for energy efficient (IE2 / IE3) motors with respect to standard (IE1) motors
3. The starting current of IE2/IE3 motors are more than IE1 motors which can result in nuisance tripping of the MCCB/MPCB. To avoid the nuisance tripping, there will be changes in selection of MCCB/MPCB with respect to existing type '2' co-ordination selection chart of standard motors
4. In selection of the MCCB/MPCB, it is normal practice to take starting current 12 times the full load current. For energy efficient motors the starting current should be taken as 16 times the full load current. This will avoid the nuisance tripping of the circuit breaker
5. In star delta type of the motors starting, during change over from star to delta contactor high inrush current flows through the system. This current usually appears 18 - 20 times the full load current. The current is given by formula mentioned below:

$$I_p = \frac{[240 \text{ (voltage at star)} + 415 \text{ (voltage at delta)}] \times 12I_n \text{ (normal starting current)}}{415}$$

$$I_p = 18I_n \text{ approx}$$

Where,

$I_p$  = Peak current

$I_n$  = Line current

Hence, for energy efficient motors as starting current is 16 times FLC the peak current during star to delta change over will be 25 times the full load current. However, this peak current lasts only for few milliseconds.

# Co-ordination of Contactors & Overload Relays with MCBs and MPCBs

## Types of MCBs

Classes MCBs and their magnetic settings are as follows:

Curve Type	Magnetic Setting (Multiples of $I_n$ )
B	3 - 5 times
C	5 - 10 times
D	10 - 20 times

'C' MCBs are popularly used for Motor protection applications.

## Problem while using an MCB for Motor Protection

Unlike a fuse unit, MCB is a peak sensing device. While providing SC protection to the motor it is imperative that the MCB does not trip on the starting transients of the motor. This care has to be taken while selecting the rating of the MCB. These transients are usually of the tune of 12 times the full load current. Now suppose a C curve MCB is selected, in order to ensure it does not trip during the starting of the motor, 12 times the motor full load current should be lesser than 5 times the MCB's nominal current.

For eg: For a motor having a full load current of 6A,  $12 \times 6 = 72A$ , A  
C curve MCB of rating =  $72/5$   
= 14.5, i.e. 15A will have to be selected

Select a 6A AC-3 rated contactor and a relay having a range of 4 - 6A

Suppose a fault occurs and the motor starts drawing a current of 60A, the MCB will not trip as 60A is lesser than  $15 \times 5 = 75A$ . As a result, the overload relay will have to give a trip signal to the contactor to break this current.

The IEC standard specifies the breaking capacity of a contactor to be 8 times its AC-3 rating. 60A is greater than  $8 \times 6 = 48A$  as a result the contactor will get damaged. This problem can be rectified by de-rating the contactor.

The second more serious problem can be described by considering the below case:

Consider a 0.16 hp motor with a full load current of 0.45A. The initial starting current will be around 5.4A. As in the earlier case a C curve MCB of 2A will have to be selected. With proper derating, a 18A Contactor is selected with a relay having rating of 0.3 - 0.5A.

Now in this case, the crossover between the relay and the MCB will take place at  $5 \times 2 = 10\text{A}$  which is 20 times the upper limit of the relay. This will cause permanent damage to the relay. There is no solution to this problem as de-rating a relay is not possible.

### **This is Type 1 Co-ordination and not Type 2**

Suppose a D curve MCB is selected, then for the above case, a  $72/10 = 7.2\text{A}$  i.e. an 8A MCB will have to be selected. Now the MCB has to trip for currents between 10-20 times its nominal current. For the worst case in which the MCB trips at 20 times (i.e. 160A), for a fault current of 140A, the overload relay will have to give a tripping command to the MCB and there will be similar consequences as in the previous case.

Thus in conclusion; while selecting an MCB for motor protection which may be a cost effective solution, one must be fully aware of the possible damages that might be caused to the contactor and overload relay.

We recommend that if a customer wants fuseless protection for a feeder, MPCB be used.

### **Caution while using MPCB in Star-Delta Motor Feeder**

In case of open transition star-delta starting (most common practice), it's an established fact that the transient current peaks during change-over from star to delta are in the order of 18 times the line current ( $I_n$ ). As the maximum magnetic threshold of a MPCB is  $13I_n$  and as it is a current peak sensing device, such conditions will definitely lead to nuisance tripping of MPCBs during change-over from star to delta mode. Both the above facts i.e. 18 times transient peak and nuisance tripping of MPCB have been verified through in-house tests as well.

Hence, to avoid nuisance tripping, it is technically correct to increase the MPCB rating for star/delta starting so that the ratio of instantaneous release setting to the motor full load current is at least 18. However, this will lead to loss in thermal overload protection offered by the MPCB (as the MPCB rating will be higher than the full load current of the motor). This aspect can be addressed by providing an additional thermal overload relay in the phase circuit.

### **Summarizing**

If star-delta type 2 chart with MPCB are offered without overload relay, it implies that the transient condition of star-delta changeover has been ignored then star-delta chart with MPCB should be with separate overload relay always.

Type-2 coordination on mobile

# ProductWhiz

Find the right product for your customer's need, in minutes!



E&A's wide switchgear range is now even easier to select from through a simple application that you can download on your phone.

ProductWhiz is a customised selection tool that helps you select the switchgear using Type 2 co-ordination, even when you're on the move. The application then lets you share the final selection with your customer over SMS or e-mail.

All our type 2 charts are available on **docWHIZ & ProductWhiz**.



Pl. download docWHIZ from  
[www.intebg.com/docwhiz](http://www.intebg.com/docwhiz)



L&T Electrical & Automation,  
ESP BizWhiz and ProductWhiz from  
Google Play Store/Apple App Store

## Type - 2 Selection Charts



Feeder Type \ SCPD	IE2			IE3		
	Fuse	MCCB	MPCB	Fuse	MCCB	MPCB
DOL MO + RTO	Pg-29	Pg-37	Pg-40	Pg-29	Pg-51	Pg-54
DOL MO + REO	Pg-30	Pg-38	Pg-40	Pg-30	Pg-52	Pg-54
SD MO + RTO	Pg-33	Pg-43	Pg-47	Pg-33	Pg-57	Pg-61
SD MO + REO	Pg-34	Pg-44	Pg-48	Pg-34	Pg-58	Pg-62
DOL MNX + MN	Pg-27	Pg-35	Pg-39	Pg-27	Pg-49	Pg-53
DOL MNX + REO	Pg-28	Pg-36	Pg-39	Pg-28	Pg-50	Pg-53
SD MNX + MN	Pg-31	Pg-41	Pg-45	Pg-31	Pg-55	Pg-59
SD MNX + REO	Pg-32	Pg-42	Pg-46	Pg-32	Pg-56	Pg-60

### Note:

- 1) The Full Load Current (FLC) indicated for 3-phase motors are of '4 pole squirrel-cage Induction motors' at full load
- 2) Contactors / S-D-Fs indicated are of the minimum ratings. Higher rating of contactors and S-D-Fs can be used
- 3) Selection chart is for standard 3-phase, squirrel cage motor with average power factor and efficiency
- 4) \* : Only size '000' fuses to be used with FN 100 S-D-F
- 5) # : Only size '00' fuses should be used with FN 160 S-D-F
- 6) Selection is valid only for complete E&A combinations. Compliance to Type-2 co-ordination is not assured in case these combinations are changed to accommodate another brand / rating of product like S-D-F / Fuse etc.
- 7) All S-D-F ratings are AC-23A as per IS/IEC 60947-3, IEC 60947-3 & EN 60947-3
- 8) Selection for motors with longer starting times can be made available on request
- 9) All the MCCBs are Instantaneous type only
- 10) Efficiency of motors are as per IS 12615: 2011  
 IE1 motor: Standard motors  
 IE2 motor: Energy efficient motors  
 IE3 motor: Premium efficient motors

## Fuse Protected DOL Starter Feeders : IE2/3 Motors



TYPE '2' Co-ordination,  $I_q=50/65$  kA at 415V, 3 $\phi$ , 50 Hz as per IS/IEC 60947-4-1 standard

SCPD Type	Contactor Type	Relay Type
FN/FNX SDF	MNX	MN
		

Sr. No.	Motor: 3 $\phi$ , 415V, 50 Hz			Contactor Type	Overload Relay		Nominal Backup Fuse		S - D - F
	hp	kW	In (A)		Type	Range (A)	Type	Rating (A)	
1	0.16	0.12	0.51	MNX 9	MN 2	0.45 - 0.75	HF	2	FN 32
2	0.25	0.18	0.6	MNX 9	MN 2	0.45 - 0.75	HF	2	FN 32
3	0.33	0.25	0.8	MNX 9	MN 2	0.6 - 1.0	HF	2	FN 32
4	0.5	0.37	1.2	MNX 9	MN 2	0.9 - 1.5	HF	4	FN 32
5	0.75	0.55	1.5	MNX 9	MN 2	1.4 - 2.3	HF	4	FN 32
6	1	0.75	2.0	MNX 9	MN 2	1.4 - 2.3	HF	6	FN 32
7	1.5	1.1	2.7	MNX 9	MN 2	2.0 - 3.3	HF	8	FN 32
8	1.75	1.3	3.0	MNX 9	MN 2	2.0 - 3.3	HF	8	FN 32
9	2	1.5	3.5	MNX 9	MN 2	3 - 5	HF	10	FN 32
10	3	2.2	4.9	MNX 9	MN 2	4.5 - 7.5	HF	16	FN 32
11	4	3	6.0	MNX 9	MN 2	4.5 - 7.5	HF	16	FN 32
12	5	3.7	7.5	MNX 9	MN 2	4.5 - 7.5	HF	20	FN 32
13	5.5	4	8.5	MNX 9	MN 2	6 - 10	HF	20	FN 32
14	7.5	5.5	11.0	MNX 12	MN 2	9 - 15	HF	32	FN 32
15	10	7.5	14.5	MNX 22	MN 2	14 - 23	HF	40	FN 63
16	12.5	9.3	17.3	MNX 25	MN 2	14 - 23	HF	50	FN 63
17	15	11	21.0	MNX 25	MN 2	14 - 23	HF	63	FN 63
18	17.5	13	24.0	MNX 25	MN 2	20 - 33	HF	63	FN 63
19	20	15	29.0	MNX 40	MN 2	20 - 33	HN, 000*	63	FN 100
20	25	18.5	35.0	MNX 40	MN 2	24 - 40	HN, 000*	80	FN 100
21	30	22	40.0	MNX 50	MN 5	30 - 50	HN, 000*	80	FN 100
22	40	30	54.0	MNX 70	MN 5	45 - 75	HN, 000*	100	FN 100
23	50	37	68.0	MNX 80	MN 5	45 - 75	HN, 000	125	FN 125
24	60	45	81.0	MNX 95	MN 5	66 - 110	HN, 000	125	FN 125
25	75	55	94.0	MNX 95	MN 5	66 - 110	HN, 00#	160	FN 160
26	100	75	130.0	MNX 140	MN 12	90 - 150	HN, 0	200	FN 200
27	110	80	139.0	MNX 140	MN 12	90 - 150	HN, 0	200	FN 200
28	120	90	157.0	MNX 185	MN 12	135 - 225	HN, 1	250	FN 250
29	150	110	189.0	MNX 225	MN 12	135 - 225	HN, 1	250	FN 250
30	170	125	207.0	MNX 250	MN 12	135 - 225	HN, 1	315	FN 315
31	180	132	226.0	MNX 250	MN 12	180 - 300	HN, 1	315	FN 315
32	200	150	248.0	MNX 300	MN 12	180 - 300	HN, 2	400	FN 400
33	215	160	270.0	MNX 300	MN 12	180 - 300	HN, 2	400	FN 400
34	240	180	298.0	MNX 400	MN 12	270 - 450	HN, 2	400	FN 400
35	270	200	336.0	MNX 400	MN 12	270 - 450	HN, 3	500	FN 630
36	300	225	360.0	MNX 400	MN 12	270 - 450	HN, 3	500	FN 630
37	335	250	420.0	MNX 550	MN 12	270 - 450	HN, 3	500	FN 630
38	370	275	440.0	MNX 550	MN 12	270 - 450	HN, 3	630	FN 630
39	425	315	529.0	MNX 550	MN 12L	340 - 570	HN, 3	630	FN 630
40	452	335	550.0	MNX 650	MN 12L	340 - 570	HN, 3	800	FN 800

## Fuse Protected DOL Starter Feeders : IE2/3 Motors

TYPE '2' Co-ordination,  $I_q=50/65$  kA at 415V, 3 $\emptyset$ , 50 Hz as per IS/IEC 60947-4-1 standard

SCPD Type	Contactor Type	Relay Type
FN/FNX SDF	MNX	REO
		

Sr. No.	Motor: 3 $\emptyset$ , 415V, 50 Hz			Contactor Type	Overload Relay		Nominal Backup Fuse		S - D - F
	hp	kW	In (A)		Type	Range (A)	Type	Rating (A)	
1	0.16	0.12	0.51	MNX 9	REO 1.1	0.15 - 0.75	HF	2	FN 32
2	0.25	0.18	0.6	MNX 9	REO 1.1	0.15 - 0.75	HF	2	FN 32
3	0.33	0.25	0.8	MNX 9	REO 1.1	0.6 - 3.0	HF	2	FN 32
4	0.5	0.37	1.2	MNX 9	REO 1.1	0.6 - 3.0	HF	4	FN 32
5	0.75	0.55	1.5	MNX 9	REO 1.1	0.6 - 3.0	HF	4	FN 32
6	1	0.75	2.0	MNX 9	REO 1.1	0.6 - 3.0	HF	6	FN 32
7	1.5	1.1	2.7	MNX 9	REO 1.1	2.4 - 12	HF	8	FN 32
8	1.75	1.3	3.0	MNX 9	REO 1.1	2.4 - 12	HF	8	FN 32
9	2	1.5	3.5	MNX 9	REO 1.1	2.4 - 12	HF	10	FN 32
10	3	2.2	4.9	MNX 9	REO 1.1	2.4 - 12	HF	16	FN 32
11	4	3	6.0	MNX 9	REO 1.1	2.4 - 12	HF	16	FN 32
12	5	3.7	7.5	MNX 9	REO 1.1	2.4 - 12	HF	20	FN 32
13	5.5	4	8.5	MNX 9	REO 1.1	2.4 - 12	HF	20	FN 32
14	7.5	5.5	11.0	MNX 12	REO 1.1	9 - 45	HF	32	FN 32
15	10	7.5	14.5	MNX 22	REO 1.1	9 - 45	HF	40	FN 63
16	12.5	9.3	17.3	MNX 25	REO 1.1	9 - 45	HF	50	FN 63
17	15	11	21.0	MNX 25	REO 1.1	9 - 45	HF	63	FN 63
18	17.5	13	24.0	MNX 25	REO 1.1	9 - 45	HF	63	FN 63
19	20	15	29.0	MNX 40	REO 1.1	9 - 45	HN, 000*	63	FN 100
20	25	18.5	35.0	MNX 40	REO 1.1	9 - 45	HN, 000*	80	FN 100
21	30	22	40.0	MNX 50	REO 1.1	9 - 45	HN, 000*	80	FN 100
22	40	30	54.0	MNX 70	REO 4	18 - 90	HN, 000*	100	FN 100
23	50	37	68.0	MNX 80	REO 4	18 - 90	HN, 000	125	FN 125
24	60	45	81.0	MNX 95	REO 4	18 - 90	HN, 000	125	FN 125
25	75	55	94.0	MNX 95	REO 4	72 - 360	HN, 00#	160	FN 160
26	100	75	130.0	MNX 140	REO 4	72 - 360	HN, 0	200	FN 200
27	110	80	139.0	MNX 140	REO 4	72 - 360	HN, 0	200	FN 200
28	120	90	157.0	MNX 185	REO 4	72 - 360	HN, 1	250	FN 250
29	150	110	189.0	MNX 225	REO 4	72 - 360	HN, 1	250	FN 250
30	170	125	207.0	MNX 250	REO 4	72 - 360	HN, 1	315	FN 315
31	180	132	226.0	MNX 250	REO 4	72 - 360	HN, 1	315	FN 315
32	200	150	248.0	MNX 300	REO 4	72 - 360	HN, 2	400	FN 400
33	215	160	270.0	MNX 300	REO 4	72 - 360	HN, 2	400	FN 400
34	240	180	298.0	MNX 400	REO 4	72 - 360	HN, 2	400	FN 400
35	270	200	336.0	MNX 400	REO 4	270 - 1350	HN, 3	500	FN 630
36	300	225	360.0	MNX 400	REO 4	270 - 1350	HN, 3	500	FN 630
37	335	250	420.0	MNX 550	REO 4	270 - 1350	HN, 3	500	FN 630
38	370	275	440.0	MNX 550	REO 4	270 - 1350	HN, 3	630	FN 630
39	425	315	529.0	MNX 550	REO 4	270 - 1350	HN, 3	630	FN 630
40	452	335	550.0	MNX 650	REO 4	270 - 1350	HN, 3	800	FN 800

Separate mounting kit required for REO 1.1



## Fuse Protected DOL Starter Feeders : IE2/3 Motors

TYPE '2' Co-ordination, Iq=50/65 kA at 415V, 3Ø, 50 Hz as per IS/IEC 60947-4-1 standard

SCPD Type	Contactor Type	Relay Type
FN/FNX SDF	MO	RTO
		

Sr. No.	Motor Ratings at 3Ø, 415V, 50 Hz			Contactor Type	Overload Relay		Nominal Backup Fuse		S - D - F
	hp	kW	In (A)		Type	Range (A)	Type	Rating (A)	
1	0.16	0.12	0.51	MO 9	RTO 1	0.31 - 0.55	HF	2	FN 32
2	0.25	0.18	0.6	MO 9	RTO 1	0.55 - 0.85	HF	2	FN 32
3	0.33	0.25	0.8	MO 9	RTO 1	0.55 - 0.85	HF	2	FN 32
4	0.5	0.37	1.2	MO 9	RTO 1	1.2 - 2	HF	4	FN 32
5	0.75	0.55	1.5	MO 9	RTO 1	1.2 - 2	HF	4	FN 32
6	1	0.75	2.0	MO 9	RTO 1	1.9 - 2.8	HF	6	FN 32
7	1.5	1.1	2.7	MO 9	RTO 1	2.4 - 3.6	HF	8	FN 32
8	1.75	1.3	3.0	MO 9	RTO 1	2.4 - 3.6	HF	8	FN 32
9	2	1.5	3.5	MO 9	RTO 1	3.5 - 5.2	HF	10	FN 32
10	3	2.2	4.9	MO 9	RTO 1	4.6 - 6.7	HF	16	FN 32
11	4	3	6.0	MO 9	RTO 1	4.6 - 6.7	HF	16	FN 32
12	5	3.7	7.5	MO 9	RTO 1	6.7 - 9.7	HF	20	FN 32
13	5.5	4	8.5	MO 9	RTO 1	6.7 - 9.7	HF	20	FN 32
14	7.5	5.5	11.0	MO 12	RTO 1	8.5 - 12.5	HF	32	FN 32
15	10	7.5	14.5	MO 25	RTO 1	12.5 - 18.5	HF	40	FN 63
16	12.5	9.3	17.3	MO 25	RTO 1	12.5 - 18.5	HF	50	FN 63
17	15	11	21.0	MO 25	RTO 1	17 - 25.5	HF	63	FN 63
18	17.5	13	24.0	MO 25	RTO 1	17 - 25.5	HF	63	FN 63
19	20	15	29.0	MO 32	RTO 1	25 - 37	HN 000*	63	FN 100
20	25	18.5	35.0	MO 40	RTO 1	25 - 37	HN, 000*	80	FN 100
21	30	22	40.0	MO 40	RTO 1	35 - 45	HN, 000*	80	FN 100
22	40	30	54.0	MO 60	RTO 2	40 - 57	HN, 000*	100	FN 100
23	50	37	68.0	MO 70	RTO 2	50 - 75	HN, 000	125	FN 125
24	60	45	81.0	MO 95	RTO 3	75 - 110	HN, 000	125	FN 125
25	75	55	94.0	MO 95	RTO 3	75 - 110	HN, 00#	160	FN 160
26	100	75	130.0	MO 140	RTO 4	105 - 156	HN, 0	200	FN 200
27	110	80	139.0	MO 140	RTO 4	105 - 156	HN, 0	200	FN 200
28	120	90	157.0	MO 185	RTO 4	138 - 201	HN, 1	250	FN 250
29	150	110	189.0	MO 185	RTO 4	138 - 201	HN, 1	250	FN 250
30	170	125	207.0	MO 225	RTO 4	201 - 291	HN, 1	315	FN 315
31	180	132	226.0	MO 250	RTO 4	201 - 291	HN, 1	315	FN 315
32	200	150	248.0	MO 250	RTO 4	201 - 291	HN, 2	400	FN 400
33	215	160	270.0	MO 300	RTO 4	201 - 291	HN, 2	400	FN 400
34	240	180	298.0	MO 300	RTO 4	255 - 375	HN, 2	400	FN 400

## Fuse Protected DOL Starter Feeders : IE2/3 Motors



TYPE '2' Co-ordination, Iq=50/65 kA at 415V, 3Ø, 50 Hz as per IS/IEC 60947-4-1 standard

SCPD Type	Contactor Type	Relay Type
FN/FNX SDF	MO	REO
		

Sr. No.	Motor Ratings at 3Ø, 415V, 50 Hz			Contactor Type	Overload Relay		Nominal Backup Fuse		S - D - F
	hp	kW	In (A)		Type	Range (A)	Type	Rating (A)	
1	0.16	0.12	0.51	MO 9	REO 1.1	0.15 – 0.75	HF	2	FN 32
2	0.25	0.18	0.6	MO 9	REO 1.1	0.15 – 0.75	HF	2	FN 32
3	0.33	0.25	0.8	MO 9	REO 1.1	0.6 – 3.0	HF	2	FN 32
4	0.5	0.37	1.2	MO 9	REO 1.1	0.6 – 3.0	HF	4	FN 32
5	0.75	0.55	1.5	MO 9	REO 1.1	0.6 – 3.0	HF	4	FN 32
6	1	0.75	2.0	MO 9	REO 1.1	0.6 – 3.0	HF	6	FN 32
7	1.5	1.1	2.7	MO 9	REO 1.1	2.4 - 12	HF	8	FN 32
8	1.75	1.3	3.0	MO 9	REO 1.1	2.4 - 12	HF	8	FN 32
9	2	1.5	3.5	MO 9	REO 1.1	2.4 - 12	HF	10	FN 32
10	3	2.2	4.9	MO 9	REO 1.1	2.4 - 12	HF	16	FN 32
11	4	3	6.0	MO 9	REO 1.1	2.4 - 12	HF	16	FN 32
12	5	3.7	7.5	MO 9	REO 1.1	2.4 - 12	HF	20	FN 32
13	5.5	4	8.5	MO 9	REO 1.1	2.4 - 12	HF	20	FN 32
14	7.5	5.5	11.0	MO 12	REO 1.1	9 - 45	HF	32	FN 32
15	10	7.5	14.5	MO 25	REO 1.1	9 – 45	HF	40	FN 63
16	12.5	9.3	17.3	MO 25	REO 1.1	9 – 45	HF	50	FN 63
17	15	11	21.0	MO 25	REO 1.1	9 - 45	HF	63	FN 63
18	17.5	13	24.0	MO 25	REO 1.1	9 - 45	HF	63	FN 63
19	20	15	29.0	MO 32	REO 1.1	9 – 45	HN 000*	63	FN 100
20	25	18.5	35.0	MO 40	REO 1.1	9 – 45	HN, 000*	80	FN 100
21	30	22	40.0	MO 40	REO 1.1	9 – 45	HN, 000*	80	FN 100
22	40	30	54.0	MO 60	REO 4	18 - 90	HN, 000*	100	FN 100
23	50	37	68.0	MO 70	REO 4	18 - 90	HN, 000	125	FN 125
24	60	45	81.0	MO 95	REO 4	18 - 90	HN, 000	125	FN 125
25	75	55	94.0	MO 95	REO 4	72 - 360	HN, 00#	160	FN 160
26	100	75	130.0	MO 140	REO 4	72 - 360	HN, 0	200	FN 200
27	110	80	139.0	MO 140	REO 4	72 - 360	HN, 0	200	FN 200
28	120	90	157.0	MO 185	REO 4	72 - 360	HN, 1	250	FN 250
29	150	110	189.0	MO 185	REO 4	72 - 360	HN, 1	250	FN 250
30	170	125	207.0	MO 225	REO 4	72 - 360	HN, 1	315	FN 315
31	180	132	226.0	MO 250	REO 4	72 - 360	HN, 1	315	FN 315
32	200	150	248.0	MO 250	REO 4	72 - 360	HN, 2	400	FN 400
33	215	160	270.0	MO 300	REO 4	72 - 360	HN, 2	400	FN 400
34	240	180	298.0	MO 300	REO 4	72 - 360	HN, 2	400	FN 400

## Fuse Protected Star Delta Starter Feeders : IE2/3 Motors



TYPE '2' Co-ordination, Iq=50 kA at 415V, 3Ø, 50 Hz as per IS/IEC 60947-4-1 standard

SCPD Type	Contactor Type	Relay Type
FN/FNX SDF	MNX	MN
		

Sr. No.	Ratings at 3Ø, 415V, 50 Hz				Contactor Type			Overload Relay		Nominal Backup Fuse		S - D - F
	hp	kW	Current, In (A)		Star	Delta	Main	Type	Range (A)	Type	Rating (A)	
			Line	Phase								
1	1	0.75	2.0	1.2	MNX 9	MNX 9	MNX 9	MN 2	0.9 - 1.5	HF	4	FN 32
2	1.5	1.1	2.7	1.6	MNX 9	MNX 9	MNX 9	MN 2	1.4 - 2.3	HF	4	FN 32
3	1.75	1.3	3.0	1.7	MNX 9	MNX 9	MNX 9	MN 2	1.4 - 2.3	HF	4	FN 32
4	2	1.5	3.5	2.0	MNX 9	MNX 9	MNX 9	MN 2	1.4 - 2.3	HF	6	FN 32
5	3	2.2	4.9	2.8	MNX 9	MNX 9	MNX 9	MN 2	2 - 3.3	HF	8	FN 32
6	4	3	6.0	3.5	MNX 9	MNX 9	MNX 9	MN 2	3 - 5	HF	8	FN 32
7	5	3.7	7.5	4.3	MNX 9	MNX 9	MNX 9	MN 2	3 - 5	HF	10	FN 32
8	5.5	4	8.5	4.9	MNX 9	MNX 9	MNX 9	MN 2	3 - 5	HF	16	FN 32
9	7.5	5.5	11.0	6.4	MNX 9	MNX 9	MNX 9	MN 2	4.5 - 7.5	HF	16	FN 32
10	10	7.5	14.5	8.4	MNX 9	MNX 9	MNX 9	MN 2	6 - 10	HF	20	FN 32
11	12.5	9.3	17.3	10.0	MNX 9	MNX 12	MNX 12	MN 2	9 - 15	HF	32	FN 32
12	15	11	21.0	12.1	MNX 9	MNX 12	MNX 12	MN 2	9 - 15	HF	32	FN 32
13	17.5	13	24.0	13.9	MNX 12	MNX 18	MNX 18	MN 2	9 - 15	HF	32	FN 32
14	20	15	29.0	16.7	MNX 12	MNX 22	MNX 22	MN 2	14 - 23	HF	40	FN 63
15	25	18.5	35.0	20.2	MNX 18	MNX 25	MNX 25	MN 2	14 - 23	HF	50	FN 63
16	30	22	40.0	23.1	MNX 18	MNX 25	MNX 25	MN 2	20 - 33	HF	63	FN 63
17	40	30	54.0	31.2	MNX 32	MNX 32	MNX 32	MN 2	20 - 33	HN, 000*	63	FN 100
18	50	37	68.0	39.3	MNX 32	MNX 50	MNX 50	MN 5	30 - 50	HN, 000*	80	FN 100
19	60	45	81.0	46.8	MNX 50	MNX 70	MNX 70	MN 5	30 - 50	HN, 000*	100	FN 100
20	75	55	94.0	54.3	MNX 50	MNX 70	MNX 70	MN 5	45 - 75	HN, 000*	100	FN 100
21	100	75	130.0	75.1	MNX 80	MNX 95	MNX 95	MN 5	66 - 110	HN, 00#	160	FN 160
22	110	80	139.0	80.3	MNX 80	MNX 95	MNX 95	MN 5	66 - 110	HN, 00#	160	FN 160
23	120	90	157.0	90.6	MNX 80	MNX 95	MNX 95	MN 5	66 - 110	HN, 00#	160	FN 160
24	150	110	189.0	109.1	MNX 95	MNX 110	MNX 110	MN 5	66 - 110	HN, 0	200	FN 200
25	170	125	207.0	119.5	MNX 95	MNX 140	MNX 140	MN 12	90 - 150	HN, 1	250	FN 250
26	180	132	226.0	130.5	MNX 110	MNX 140	MNX 140	MN 12	90 - 150	HN, 1	250	FN 250
27	200	150	248.0	143.2	MNX 110	MNX 185	MNX 185	MN 12	135 - 225	HN, 1	250	FN 250
28	215	160	270.0	155.9	MNX 140	MNX 225	MNX 225	MN 12	135 - 225	HN, 1	315	FN 315
29	240	180	298.0	172.1	MNX 140	MNX 225	MNX 225	MN 12	135 - 225	HN, 1	315	FN 315
30	270	200	336.0	194.0	MNX 250	MNX 300	MNX 300	MN 12	135 - 225	HN, 2	400	FN 400
31	300	225	360.0	207.9	MNX 250	MNX 300	MNX 300	MN 12	135 - 225	HN, 2	400	FN 400
32	335	250	420.0	242.5	MNX 300	MNX 400	MNX 400	MN 12	180 - 300	HN, 3	500	FN 630
33	370	275	440.0	254.0	MNX 300	MNX 400	MNX 400	MN 12	180 - 300	HN, 3	500	FN 630
34	425	315	529.0	305.4	MNX 400	MNX 550	MNX 550	MN 12	270 - 450	HN, 3	630	FN 630
35	452	335	550.0	317.6	MNX 400	MNX 550	MNX 550	MN 12	270 - 450	HN, 3	630	FN 630
36	475	355	589.0	340.1	MNX 400	MNX 550	MNX 550	MN 12	270 - 450	HN, 3	630	FN 630
37	502	375	615.0	355.1	MNX 400	MNX 550	MNX 550	MN 12	270 - 450	HN, 3	630	FN 630
38	535	400	674.0	389.1	MNX 550	MNX 650	MNX 650	MN 12	270 - 450	HN, 3	800	FN 800

## Fuse Protected Star Delta Starter Feeders : IE2/3 Motors

TYPE '2' Co-ordination, Iq=50 kA at 415V, 3Ø, 50 Hz as per IS/IEC 60947-4-1 standard

SCPD Type	Contactor Type	Relay Type
FN/FNX SDF	MNX	REO
		

Sr. No.	Ratings at 3Ø, 415V, 50 Hz				Contactor Type			Overload Relay		Nominal Backup Fuse		S - D - F
	hp	kW	Current, In (A)		Star	Delta	Main	Type	Range (A)	Type	Rating (A)	
			Line	Phase								
1	1	0.75	2.0	1.2	MNX 9	MNX 9	MNX 9	REO 1.1	0.6 – 3	HF	4	FN 32
2	1.5	1.1	2.7	1.6	MNX 9	MNX 9	MNX 9	REO 1.1	0.6 – 3	HF	4	FN 32
3	1.75	1.3	3.0	1.7	MNX 9	MNX 9	MNX 9	REO 1.1	0.6 – 3	HF	4	FN 32
4	2	1.5	3.5	2.0	MNX 9	MNX 9	MNX 9	REO 1.1	0.6 – 3	HF	6	FN 32
5	3	2.2	4.9	2.8	MNX 9	MNX 9	MNX 9	REO 1.1	2.4 – 12	HF	8	FN 32
6	4	3	6.0	3.5	MNX 9	MNX 9	MNX 9	REO 1.1	2.4 – 12	HF	8	FN 32
7	5	3.7	7.5	4.3	MNX 9	MNX 9	MNX 9	REO 1.1	2.4 – 12	HF	10	FN 32
8	5.5	4	8.5	4.9	MNX 9	MNX 9	MNX 9	REO 1.1	2.4 – 12	HF	16	FN 32
9	7.5	5.5	11.0	6.4	MNX 9	MNX 9	MNX 9	REO 1.1	2.4 – 12	HF	16	FN 32
10	10	7.5	14.5	8.4	MNX 9	MNX 9	MNX 9	REO 1.1	2.4 – 12	HF	20	FN 32
11	12.5	9.3	17.3	10.0	MNX 9	MNX 12	MNX 12	REO 1.1	2.4 – 12	HF	32	FN 32
12	15	11	21.0	12.1	MNX 9	MNX 12	MNX 12	REO 1.1	9 – 45	HF	32	FN 32
13	17.5	13	24.0	13.9	MNX 12	MNX 18	MNX 18	REO 1.1	9 – 45	HF	32	FN 32
14	20	15	29.0	16.7	MNX 12	MNX 22	MNX 22	REO 1.1	9 – 45	HF	40	FN 63
15	25	18.5	35.0	20.2	MNX 18	MNX 25	MNX 25	REO 1.1	9 – 45	HF	50	FN 63
16	30	22	40.0	23.1	MNX 18	MNX 25	MNX 25	REO 1.1	9 – 45	HF	63	FN 63
17	40	30	54.0	31.2	MNX 32	MNX 32	MNX 32	REO 1.1	9 – 45	HN, 000*	63	FN 100
18	50	37	68.0	39.3	MNX 32	MNX 50	MNX 50	REO 1.1	9 – 45	HN, 000*	80	FN 100
19	60	45	81.0	46.8	MNX 50	MNX 70	MNX 70	REO 4	18 - 90	HN, 000*	100	FN 100
20	75	55	94.0	54.3	MNX 50	MNX 70	MNX 70	REO 4	18 - 90	HN, 000*	100	FN 100
21	100	75	130.0	75.1	MNX 80	MNX 95	MNX 95	REO 4	18 - 90	HN, 00#	160	FN 160
22	110	80	139.0	80.3	MNX 80	MNX 95	MNX 95	REO 4	18 - 90	HN, 00#	160	FN 160
23	120	90	157.0	90.6	MNX 80	MNX 95	MNX 95	REO 4	72 - 360	HN, 00#	160	FN 160
24	150	110	189.0	109.1	MNX 95	MNX 110	MNX 110	REO 4	72 - 360	HN, 0	200	FN 200
25	170	125	207.0	119.5	MNX 95	MNX 140	MNX 140	REO 4	72 - 360	HN, 1	250	FN 250
26	180	132	226.0	130.5	MNX 110	MNX 140	MNX 140	REO 4	72 - 360	HN, 1	250	FN 250
27	200	150	248.0	143.2	MNX 110	MNX 185	MNX 185	REO 4	72 - 360	HN, 1	250	FN 250
28	215	160	270.0	155.9	MNX 140	MNX 225	MNX 225	REO 4	72 - 360	HN, 1	315	FN 315
29	240	180	298.0	172.1	MNX 140	MNX 225	MNX 225	REO 4	72 - 360	HN, 1	315	FN 315
30	270	200	336.0	194.0	MNX 250	MNX 300	MNX 300	REO 4	72 - 360	HN, 2	400	FN 400
31	300	225	360.0	207.9	MNX 250	MNX 300	MNX 300	REO 4	72 - 360	HN, 2	400	FN 400
32	335	250	420.0	242.5	MNX 300	MNX 400	MNX 400	REO 4	72 - 360	HN, 3	500	FN 630
33	370	275	440.0	254.0	MNX 300	MNX 400	MNX 400	REO 4	72 - 360	HN, 3	500	FN 630
34	425	315	529.0	305.4	MNX 400	MNX 550	MNX 550	REO 4	72 - 360	HN, 3	630	FN 630
35	452	335	550.0	317.6	MNX 400	MNX 550	MNX 550	REO 4	72 - 360	HN, 3	630	FN 630
36	475	355	589.0	340.1	MNX 400	MNX 550	MNX 550	REO 4	270 - 1350	HN, 3	630	FN 630
37	502	375	615.0	355.1	MNX 400	MNX 550	MNX 550	REO 4	270 - 1350	HN, 3	630	FN 630
38	535	400	674.0	389.1	MNX 550	MNX 650	MNX 650	REO 4	270 - 1350	HN, 3	800	FN 800

Separate mounting kit required for REO 1.1

## Fuse Protected Star Delta Starter Feeders : IE2/3 Motors

TYPE '2' Co-ordination, Iq=50 kA at 415V, 3Ø, 50 Hz as per IS/IEC 60947-4-1 standard

SCPD Type	Contactor Type	Relay Type
FN/FNX SDF	MO	RTO
		

Sr. No.	Ratings at 3Ø, 415V, 50 Hz				Contactor Type			Overload Relay		Nominal Backup Fuse		S - D - F
	hp	kW	Current, In (A)		Star	Line	Delta	Type	Range (A)	Type	Rating (A)	
			Line	Phase								
1	1	0.75	2.0	1.2	MO 9	MO 9	MO 9	RTO 1	1.2 - 2.0	HF	4	FN 32
2	1.5	1.1	2.7	1.6	MO 9	MO 9	MO 9	RTO 1	1.2 - 2.0	HF	4	FN 32
3	1.75	1.3	3.0	1.7	MO 9	MO 9	MO 9	RTO 1	1.2 - 2.0	HF	4	FN 32
4	2	1.5	3.5	2.0	MO 9	MO 9	MO 9	RTO 1	1.9 - 2.8	HF	6	FN 32
5	3	2.2	4.9	2.8	MO 9	MO 9	MO 9	RTO 1	2.4 - 3.6	HF	8	FN 32
6	4	3	6.0	3.5	MO 9	MO 9	MO 9	RTO 1	3.5 - 5.2	HF	8	FN 32
7	5	3.7	7.5	4.3	MO 9	MO 9	MO 9	RTO 1	3.5 - 5.2	HF	10	FN 32
8	5.5	4	8.5	4.9	MO 9	MO 9	MO 9	RTO 1	4.6 - 6.7	HF	16	FN 32
9	7.5	5.5	11.0	6.4	MO 9	MO 9	MO 9	RTO 1	4.6 - 6.7	HF	16	FN 32
10	10	7.5	14.5	8.4	MO 9	MO 9	MO 9	RTO 1	6.7 - 9.7	HF	20	FN 32
11	12.5	9.3	17.3	10.0	MO 9	MO 12	MO 12	RTO 1	8.5 - 12.5	HF	32	FN 32
12	15	11	21.0	12.1	MO 9	MO 12	MO 12	RTO 1	8.5 - 12.5	HF	32	FN 32
13	17.5	13	24.0	13.9	MO 12	MO 18	MO 18	RTO 1	12.5 - 18.5	HF	32	FN 32
14	20	15	29.0	16.7	MO 12	MO 18	MO 18	RTO 1	12.5 - 18.5	HF	40	FN 63
15	25	18.5	35.0	20.2	MO 18	MO 25	MO 25	RTO 1	17 - 25.5	HF	50	FN 63
16	30	22	40.0	23.1	MO 18	MO 25	MO 25	RTO 1	17 - 25.5	HF	63	FN 63
17	40	30	54.0	31.2	MO 32	MO 32	MO 32	RTO 1	25 - 37	HN, 000 *	63	FN 100
18	50	37	68.0	39.3	MO 32	MO 40	MO 40	RTO 1	35 - 45	HN, 000 *	80	FN 100
19	60	45	81.0	46.8	MO 50	MO 60	MO 60	RTO 2	40 - 57	HN, 000*	100	FN 100
20	75	55	94.0	54.3	MO 50	MO 60	MO 60	RTO 2	50 - 75	HN, 000*	100	FN 100
21	100	75	130.0	75.1	MO 80	MO 80	MO 80	RTO 3	75 - 110	HN, 00#	160	FN 160
22	110	80	139.0	80.3	MO 80	MO 95	MO 95	RTO 3	75 - 110	HN, 00#	160	FN 160
23	120	90	157.0	90.6	MO 80	MO 95	MO 95	RTO 3	75 - 110	HN, 00#	160	FN 160
24	150	110	189.0	109.1	MO 95	MO 110	MO 110	RTO 3	75 - 110	HN, 0	200	FN 200
25	170	125	207.0	119.5	MO 95	MO 140	MO 140	RTO 4	105 -156	HN, 1	250	FN 250
26	180	132	226.0	130.5	MO 110	MO 140	MO 140	RTO 4	105- 156	HN, 1	250	FN 250
27	200	150	248.0	143.2	MO 110	MO 185	MO 185	RTO 4	105 - 156	HN, 1	250	FN 250
28	215	160	270.0	155.9	MO 140	MO 185	MO 185	RTO 4	138 - 201	HN, 1	315	FN 315
29	240	180	298.0	172.1	MO 140	MO 185	MO 185	RTO 4	138- 201	HN, 1	315	FN 315
30	270	200	336.0	194.0	MO 225	MO 250	MO 250	RTO 4	138 - 201	HN, 2	400	FN 400
31	300	225	360.0	207.9	MO 225	MO 250	MO 250	RTO 4	201 - 291	HN, 2	400	FN 400
32	335	250	420.0	242.5	MO 250	MO 300	MO 300	RTO 4	201 - 291	HN, 3	500	FN 630
33	370	275	440.0	254.0	MO 300	MO 300	MO 300	RTO 4	201 - 291	HN, 3	500	FN 630

## Fuse Protected Star Delta Starter Feeders : IE2/3 Motors



TYPE '2' Co-ordination, Iq=50 kA at 415V, 3Ø, 50 Hz as per IS/IEC 60947-4-1 standard

SCPD Type	Contactor Type	Relay Type
FN/FNX SDF	MO	REO
		

Sr. No.	Ratings at 3Ø, 415V, 50 Hz				Contactor Type			Overload Relay		Nominal Backup Fuse		S - D - F
	hp	kW	Current, In (A)		Star	Line	Delta	Type	Range (A)	Type	Rating (A)	
			Line	Phase								
1	1	0.75	2.0	1.2	MO 9	MO 9	MO 9	REO 1.1	0.6 - 3	HF	4	FN 32
2	1.5	1.1	2.7	1.6	MO 9	MO 9	MO 9	REO 1.1	0.6 - 3	HF	4	FN 32
3	1.75	1.3	3.0	1.7	MO 9	MO 9	MO 9	REO 1.1	0.6 - 3	HF	4	FN 32
4	2	1.5	3.5	2.0	MO 9	MO 9	MO 9	REO 1.1	0.6 - 3	HF	6	FN 32
5	3	2.2	4.9	2.8	MO 9	MO 9	MO 9	REO 1.1	2.4 - 12	HF	8	FN 32
6	4	3	6.0	3.5	MO 9	MO 9	MO 9	REO 1.1	2.4 - 12	HF	8	FN 32
7	5	3.7	7.5	4.3	MO 9	MO 9	MO 9	REO 1.1	2.4 - 12	HF	10	FN 32
8	5.5	4	8.5	4.9	MO 9	MO 9	MO 9	REO 1.1	2.4 - 12	HF	16	FN 32
9	7.5	5.5	11.0	6.4	MO 9	MO 9	MO 9	REO 1.1	2.4 - 12	HF	16	FN 32
10	10	7.5	14.5	8.4	MO 9	MO 9	MO 9	REO 1.1	2.4 - 12	HF	20	FN 32
11	12.5	9.3	17.3	10.0	MO 9	MO 12	MO 12	REO 1.1	2.4 - 12	HF	32	FN 32
12	15	11	21.0	12.1	MO 9	MO 12	MO 12	REO 1.1	9 - 45	HF	32	FN 32
13	17.5	13	24.0	13.9	MO 12	MO 18	MO 18	REO 1.1	9 - 45	HF	32	FN 32
14	20	15	29.0	16.7	MO 12	MO 18	MO 18	REO 1.1	9 - 45	HF	40	FN 63
15	25	18.5	35.0	20.2	MO 18	MO 25	MO 25	REO 1.1	9 - 45	HF	50	FN 63
16	30	22	40.0	23.1	MO 18	MO 25	MO 25	REO 1.1	9 - 45	HF	63	FN 63
17	40	30	54.0	31.2	MO 32	MO 32	MO 32	REO 1.1	9 - 45	HN, 000 *	63	FN 100
18	50	37	68.0	39.3	MO 32	MO 40	MO 40	REO 1.1	9 - 45	HN, 000 *	80	FN 100
19	60	45	81.0	46.8	MO 50	MO 60	MO 60	REO 4	18 - 90	HN, 000*	100	FN 100
20	75	55	94.0	54.3	MO 50	MO 60	MO 60	REO 4	18 - 90	HN, 000*	100	FN 100
21	100	75	130.0	75.1	MO 80	MO 80	MO 80	REO 4	18 - 90	HN, 00#	160	FN 160
22	110	80	139.0	80.3	MO 80	MO 95	MO 95	REO 4	18 - 90	HN, 00#	160	FN 160
23	120	90	157.0	90.6	MO 80	MO 95	MO 95	REO 4	72 - 360	HN, 00#	160	FN 160
24	150	110	189.0	109.1	MO 95	MO 110	MO 110	REO 4	72 - 360	HN, 0	200	FN 200
25	170	125	207.0	119.5	MO 95	MO 140	MO 140	REO 4	72 - 360	HN, 1	250	FN 250
26	180	132	226.0	130.5	MO 110	MO 140	MO 140	REO 4	72 - 360	HN, 1	250	FN 250
27	200	150	248.0	143.2	MO 110	MO 185	MO 185	REO 4	72 - 360	HN, 1	250	FN 250
28	215	160	270.0	155.9	MO 140	MO 185	MO 185	REO 4	72 - 360	HN, 1	315	FN 315
29	240	180	298.0	172.1	MO 140	MO 185	MO 185	REO 4	72 - 360	HN, 1	315	FN 315
30	270	200	336.0	194.0	MO 225	MO 250	MO 250	REO 4	72 - 360	HN, 2	400	FN 400
31	300	225	360.0	207.9	MO 225	MO 250	MO 250	REO 4	72 - 360	HN, 2	400	FN 400
32	335	250	420.0	242.5	MO 250	MO 300	MO 300	REO 4	72 - 360	HN, 3	500	FN 630
33	370	275	440.0	254.0	MO 300	MO 300	MO 300	REO 4	72 - 360	HN, 3	500	FN 630

## Fuseless Protection for DOL Starter Feeders : IE2 Motors

TYPE '2' Co-ordination, Iq=50 kA at 415V, 3Ø, 50 Hz as per IS/IEC 60947-4-1 standard



SCPD Type	Contactor Type	Relay Type
DN MCCB	MNX	MN
		

Sr. No.	Motor: 3Ø, 415V, 50 Hz			Contactor Type	Overload Relay			MCCB	
	hp	kW	FLC, In (A)		Type	Range (A)		Type	Rating (A)
1	0.5	0.37	1.2	MNX 50	REO 1.1	0.6	3	DN0-100M	32
2	0.75	0.55	1.5	MNX 50	REO 1.1	0.6	3	DN0-100M	32
3	1.0	0.75	2	MNX 50	REO 1.1	0.6	3	DN0-100M	32
4	1.5	1.1	2.7	MNX 50	REO 1.1	2.4	12	DN0-100M	32
5	1.75	1.3	3	MNX 50	REO 1.1	2.4	12	DN0 -100M	32
6	2	1.5	3.5	MNX 50	REO 1.1	2.4	12	DN0-100M	32
7	3.0	2.2	4.9	MNX 50	REO 1.1	2.4	12	DN0-100M	32
8	4	3	6	MNX 50	REO 1.1	2.4	12	DN0-100M	32
9	5.0	3.7	7.5	MNX 50	REO 1.1	2.4	12	DN0-100M	32
10	5.5	4	8.5	MNX 50	REO 1.1	2.4	12	DN0-100M	32
11	7.5	5.5	11	MNX 50	REO 1.1	9	45	DN0-100M	32
12	10	7.5	14.5	MNX 50	REO 1.1	9	45	DN0-100M	32
13	12.5	9.3	17.3	MNX 50	MN5	14	23	DN0-100M	32
14	15	11	21	MNX 50	MN5	20	33	DN0-100M	40
15	17.5	13	24	MNX 50	MN5	20	33	DN0-100M	40
16	20	15	29	MNX 70	MN5	20	33	DN0-100M	50
17	25	18.5	35	MNX 70	MN5	30	50	DN0-100M	63
18	30	22	40	MNX 80	MN5	30	50	DN0-100M	80
19	40	30	54	MNX 95	MN5	45	75	DN0-100M	100
20	50	37	68	MNX 95	MN5	66	110	DN1-160M	100
21	60	45	81	MNX 110	MN5	66	110	DN1-160M	125
22	75	55	94	MNX 110	MN5	66	110	DN1-160M	160
23	100	75	130	MNX 185	MN12	90	150	DN2-250M	200
24	110	80	139	MNX 225	MN12	90	150	DN2-250M	250
25	120	90	157	MNX 225	MN12	135	225	DN2-250M	250
26	150	110	189	MNX 250	MN12	135	225	DN3-400M	320
27	170	125	207	MNX 250	MN12	180	300	DN3-400M	320
28	180	132	226	MNX 300	MN12	180	300	DN3-400M	400
29	200	150	248	MNX 300	MN12	180	300	DN3-400M	400
30	215	160	270	MNX 300	MN12	180	300	DN3-400M	400
31	240	180	298	MNX 400	MN12	270	450	DN3-630M	500
32	270	200	336	MNX 400	MN12	270	450	DN3-630M	500
33	300	225	360	MNX 550	MN12	270	450	DN3-630M	630
34	335	250	420	MNX 550	Mn12	270	450	DN3-630M	630

Separate mounting kit required for REO 1.1

## Fuseless Protection for DOL Starter Feeders : IE2 Motors

TYPE '2' Co-ordination, Iq=50 kA at 415V, 3Ø, 50 Hz as per IS/IEC 60947-4-1 standard

SCPD Type	Contactor Type	Relay Type
DN MCCB	MNX	REO
		

Sr. No.	Motor: 3Ø, 415V, 50 Hz			Contactor Type	Overload Relay			MCCB	
	hp	kW	FLC, In (A)		Type	Range (A)		Type	Rating (A)
1	0.5	0.37	1.2	MNX 50	REO 1.1	0.6	3	DN0-100M	32
2	0.75	0.55	1.5	MNX 50	REO 1.1	0.6	3	DN0-100M	32
3	1.0	0.75	2	MNX 50	REO 1.1	0.6	3	DN0-100M	32
4	1.5	1.1	2.7	MNX 50	REO 1.1	2.4	12	DN0-100M	32
5	1.75	1.3	3	MNX 50	REO 1.1	2.4	12	DN0 -100M	32
6	2	1.5	3.5	MNX 50	REO 1.1	2.4	12	DN0-100M	32
7	3.0	2.2	4.9	MNX 50	REO 1.1	2.4	12	DN0-100M	32
8	4	3	6	MNX 50	REO 1.1	2.4	12	DN0-100M	32
9	5.0	3.7	7.5	MNX 50	REO 1.1	2.4	12	DN0-100M	32
10	5.5	4	8.5	MNX 50	REO 1.1	2.4	12	DN0-100M	32
11	7.5	5.5	11	MNX 50	REO 1.1	9	45	DN0-100M	32
12	10	7.5	14.5	MNX 50	REO 1.1	9	45	DN0-100M	32
13	12.5	9.3	17.3	MNX 50	REO 1.1	9	45	DN0-100M	32
14	15	11	21	MNX 50	REO 1.1	9	45	DN0-100M	40
15	17.5	13	24	MNX 50	REO 1.1	9	45	DN0-100M	40
16	20	15	29	MNX 70	REO 1.1	9	45	DN0-100M	50
17	25	18.5	35	MNX 70	REO 1.1	9	45	DN0-100M	63
18	30	22	40	MNX 80	REO 1.1	9	45	DN0-100M	80
19	40	30	54	MNX 95	REO 4	18	90	DN0-100M	100
20	50	37	68	MNX 95	REO 4	18	90	DN1-160M	100
21	60	45	81	MNX 110	REO 4	18	90	DN1-160M	125
22	75	55	94	MNX 110	REO 4	72	360	DN1-160M	160
23	100	75	130	MNX 185	REO 4	72	360	DN2-250M	200
24	110	80	139	MNX 225	REO 4	72	360	DN2-250M	250
25	120	90	157	MNX 225	REO 4	72	360	DN2-250M	250
26	150	110	189	MNX 250	REO 4	72	360	DN3-400M	320
27	170	125	207	MNX 250	REO 4	72	360	DN3-400M	320
28	180	132	226	MNX 300	REO 4	72	360	DN3-400M	400
29	200	150	248	MNX 300	REO 4	72	360	DN3-400M	400
30	215	160	270	MNX 300	REO 4	72	360	DN3-400M	400
31	240	180	298	MNX 400	REO 4	72	360	DN3-630M	500
32	270	200	336	MNX 400	REO 4	72	360	DN3-630M	500
33	300	225	360	MNX 550	REO 4	270	1350	DN3-630M	630
34	335	250	420	MNX 550	REO 4	270	1350	DN3-630M	630

Separate mounting kit required for REO 1.1



## Fuseless Protection for DOL Starter Feeders : IE2 Motors

TYPE '2' Co-ordination, Iq=50 kA at 415V, 3Ø, 50 Hz as per IS/IEC 60947-4-1 standard

SCPD Type	Contactors Type	Relay Type
DN MCCB	MO	RTO
		

Sr. No.	Motor Ratings at 3Ø, 415V, 50 Hz			Contactors Type	Overload Relay			MCCB	
	hp	kW	FLC, In (A)		Type	Range (A)	Type	Rating (A)	
1	0.5	0.37	1.2	MO 50	REO 1.1	0.6	3	DN0 - 100M	32
2	0.75	0.55	1.5	MO 50	REO 1.1	0.6	3	DN0 - 100M	32
3	1	0.75	2	MO 50	REO 1.1	0.6	3	DN0 - 100M	32
4	1.5	1.1	2.7	MO 50	REO 1.1	2.4	12	DN0 - 100M	32
5	1.75	1.3	3	MO 50	REO 1.1	2.4	12	DN0 - 100M	32
6	2	1.5	3.5	MO 50	REO 1.1	2.4	12	DN0 - 100M	32
7	3	2.2	4.9	MO 50	REO 1.1	2.4	12	DN0 - 100M	32
8	4	3	6	MO 50	REO 1.1	2.4	12	DN0 - 100M	32
9	5	3.7	7.5	MO 50	REO 1.1	2.4	12	DN0 - 100M	32
10	5.5	4	8.5	MO 50	REO 1.1	2.4	12	DN0 - 100M	32
11	7.5	5.5	11	MO 50	REO 1.1	9	45	DN0 - 100M	32
12	10	7.5	14.5	MO 50	REO 1.1	9	45	DN0 - 100M	32
13	12.5	9.3	17.3	MO 50	RTO-2	15	21	DN0 - 100M	32
14	15	11	21	MO 50	RTO-2	20	31	DN0 - 100M	40
15	17.5	13	24	MO 50	RTO-2	20	31	DN0 - 100M	40
16	20	15	29	MO 50	RTO-2	20	31	DN0 - 100M	50
17	25	18.5	35	MO 60	RTO-2	30	43	DN0 - 100M	63
18	30	22	40	MO 80	RTO-3	37	49	DN0 - 100M	80
19	40	30	54	MO 80	RTO-3	47	62	DN0 - 100M	100
20	50	37	68	MO 95	RTO-3	60	78	DN1 - 160M	100
21	60	45	81	MO 95	RTO-3	75	110	DN1 - 160M	125
22	75	55	94	MO 140	RTO-4	72	108	DN1 - 160M	160
23	100	75	130	MO 185	RTO-4	105	156	DN2 - 250M	200
24	110	80	139	MO 185	RTO-4	105	156	DN2 - 250M	250
25	120	90	157	MO 185	RTO-4	138	201	DN2 - 250M	250
26	150	110	189	MO 250	RTO-4	138	201	DN3 - 400M	320
27	170	125	207	MO 250	RTO-4	201	291	DN3 - 400M	320
28	180	132	226	MO 300	RTO-4	201	291	DN3 - 400M	400
29	200	150	248	MO 300	RTO-4	201	291	DN3 - 400M	400
30	215	160	270	MO 300	RTO-4	201	291	DN3 - 400M	400

Separate mounting kit required for REO 1.1

## Fuseless Protection for DOL Starter Feeders : IE2 Motors

TYPE '2' Co-ordination, Iq=50 kA at 415V, 3Ø, 50 Hz as per IS/IEC 60947-4-1 standard



SCPD Type	Contactor Type	Relay Type
DN MCCB	MO	REO
		

Sr. No.	Motor Ratings at 3Ø, 415V, 50 Hz			Contactor Type	Overload Relay			MCCB	
	hp	kW	FLC, In (A)		Type	Range (A)	Type	Rating (A)	
1	0.5	0.37	1.2	MO 50	REO 1.1	0.6	3	DN0 - 100M	32
2	0.75	0.55	1.5	MO 50	REO 1.1	0.6	3	DN0 - 100M	32
3	1	0.75	2	MO 50	REO 1.1	0.6	3	DN0 - 100M	32
4	1.5	1.1	2.7	MO 50	REO 1.1	2.4	12	DN0 - 100M	32
5	1.75	1.3	3	MO 50	REO 1.1	2.4	12	DN0 - 100M	32
6	2	1.5	3.5	MO 50	REO 1.1	2.4	12	DN0 - 100M	32
7	3	2.2	4.9	MO 50	REO 1.1	2.4	12	DN0 - 100M	32
8	4	3	6	MO 50	REO 1.1	2.4	12	DN0 - 100M	32
9	5	3.7	7.5	MO 50	REO 1.1	2.4	12	DN0 - 100M	32
10	5.5	4	8.5	MO 50	REO 1.1	2.4	12	DN0 - 100M	32
11	7.5	5.5	11	MO 50	REO 1.1	9	45	DN0 - 100M	32
12	10	7.5	14.5	MO 50	REO 1.1	9	45	DN0 - 100M	32
13	12.5	9.3	17.3	MO 50	REO 1.1	9	45	DN0 - 100M	32
14	15	11	21	MO 50	REO 1.1	9	45	DN0 - 100M	40
15	17.5	13	24	MO 50	REO 1.1	9	45	DN0 - 100M	40
16	20	15	29	MO 50	REO 1.1	9	45	DN0 - 100M	50
17	25	18.5	35	MO 60	REO 1.1	9	45	DN0 - 100M	63
18	30	22	40	MO 80	REO 1.1	9	45	DN0 - 100M	80
19	40	30	54	MO 80	REO 4	18	90	DN0 - 100M	100
20	50	37	68	MO 95	REO 4	18	90	DN1 - 160M	100
21	60	45	81	MO 95	REO 4	18	90	DN1 - 160M	125
22	75	55	94	MO 140	REO 4	72	360	DN1 - 160M	160
23	100	75	130	MO 185	REO 4	72	360	DN2 - 250M	200
24	110	80	139	MO 185	REO 4	72	360	DN2 - 250M	250
25	120	90	157	MO 185	REO 4	72	360	DN2 - 250M	250
26	150	110	189	MO 250	REO 4	72	360	DN3 - 400M	320
27	170	125	207	MO 250	REO 4	72	360	DN3 - 400M	320
28	180	132	226	MO 300	REO 4	72	360	DN3 - 400M	400
29	200	150	248	MO 300	REO 4	72	360	DN3 - 400M	400
30	215	160	270	MO 300	REO 4	72	360	DN3 - 400M	400

Separate mounting kit required for REO 1.1

## Fuseless Protection for DOL Starter Feeders : IE2 Motors



TYPE '2' Co-ordination, Iq=50 kA at 415V, 3Ø, 50 Hz as per IS/IEC 60947-4-1 standard

SCPD Type	Contactor Type
MOG MPCB	MNX
	

Sr. No.	Motor: 3Ø, 415V, 50 Hz			Contactor Type	MPCB	
	hp	kW	FLC, In (A)		Type	Rating (A)
1	0.16	0.12	0.51	MNX 9	MOG-S1/MOG-H1	0.4 - 0.63
2	0.25	0.18	0.6	MNX 9	MOG-S1/MOG-H1	0.4 - 0.63
3	0.33	0.25	0.8	MNX 9	MOG-S1/MOG-H1	0.63 - 1
4	0.5	0.37	1.2	MNX 9	MOG-S1/MOG-H1	1 - 1.6
5	0.75	0.55	1.5	MNX 9	MOG-S1/MOG-H1	1 - 1.6
6	1	0.75	2.0	MNX 9	MOG-S1/MOG-H1	1.6 - 2.5
7	1.5	1.1	2.7	MNX 12	MOG-S1/MOG-H1	2.5 - 4
8	1.75	1.3	3.0	MNX 12	MOG-S1/MOG-H1	2.5 - 4
9	2	1.5	3.5	MNX 12	MOG-S1/MOG-H1	2.5 - 4
10	3	2.2	4.9	MNX 22	MOG-S1/MOG-H1	4 - 6.3
11	4	3	6.0	MNX 22	MOG-S1/MOG-H1	4 - 6.3
12	5	3.7	7.5	MNX 25	MOG-S1/MOG-H1	6.3 - 10
13	5.5	4	8.5	MNX 25	MOG-S1/MOG-H1	6.3 - 10
14	7.5	5.5	11.0	MNX 25	MOG-S1/MOG-H1	9 - 13
15	10	7.5	14.5	MNX 25	MOG-S1/MOG-H1	11 - 16
16	12.5	9.3	17.3	MNX 32	MOG-S1/MOG-H1	14 - 20
17	15	11	21.0	MNX 40	MOG-S1/MOG-H1	19 - 25
18	17.5	13	24.0	MNX 50	MOG-S1/MOG-H1	24 - 32
19	20	15	29.0	MNX 50	MOG-S1/MOG-H1	24 - 32
20	25	18.5	35.0	MNX 70	MOG-H2	28 - 40
21	30	22	40.0	MNX 70	MOG-H2	35 - 50
22	40	30	54.0	MNX 80	MOG-H2	45 - 63

## Fuseless Protection for DOL Starter Feeders : IE2 Motors



TYPE '2' Co-ordination, Iq=50 kA at 415V, 3Ø, 50 Hz as per IS/IEC 60947-4-1 standard

SCPD Type	Contactor Type
MOG MPCB	MO
	

Sr. No.	Motor Ratings at 3Ø, 415V, 50 Hz			Contactor Type	MPCB	
	hp	kW	FLC in (A)		Type	Rating (A)
1	0.16	0.12	0.51	MO 9	MOG-S1 / MOG-H1	0.4 - 0.63
2	0.25	0.18	0.6	MO 9	MOG-S1 / MOG-H1	0.4 - 0.63
3	0.33	0.25	0.8	MO 9	MOG-S1 / MOG-H1	0.63 - 1
4	0.5	0.37	1.2	MO 9	MOG-S1 / MOG-H1	1 - 1.6
5	0.75	0.55	1.5	MO 9	MOG-S1 / MOG-H1	1 - 1.6
6	1	0.75	2.0	MO 9	MOG-S1 / MOG-H1	1.6 - 2.5
7	1.5	1.1	2.7	MO 12	MOG-S1 / MOG-H1	2.5 - 4
8	1.75	1.3	3.0	MO 12	MOG-S1 / MOG-H1	2.5 - 4
9	2	1.5	3.5	MO 12	MOG-S1 / MOG-H1	2.5 - 4
10	3	2.2	4.9	MO 18	MOG-S1 / MOG-H1	4 - 6.3
11	4	3	6.0	MO 18	MOG-S1 / MOG-H1	4 - 6.3
12	5	3.7	7.5	MO 25	MOG-S1 / MOG-H1	6.3 - 10
13	5.5	4	8.5	MO 25	MOG-S1 / MOG-H1	6.3 - 10
14	7.5	5.5	11.0	MO 25	MOG-S1 / MOG-H1	9 - 13
15	10	7.5	14.5	MO 25	MOG-S1 / MOG-H1	11 - 16
16	12.5	9.3	17.3	MO 32	MOG-S1 / MOG-H1	14 - 20
17	15	11	21.0	MO 32	MOG-S1 / MOG-H1	19 - 25
18	17.5	13	24.0	MO 45	MOG-S1 / MOG-H1	24 - 32
19	20	15	29.0	MO 45	MOG-S1 / MOG-H1	24 - 32
20	25	18.5	35.0	MO 50	MOG-H2	28 - 40
21	30	22	40.0	MO 50	MOG-H2	35 - 50
22	40	30	54.0	MO 80	MOG-H2	45 - 63

## Fuseless Protection for Star Delta Starter Feeders : IE2 Motors

TYPE '2' Co-ordination, I<sub>q</sub>=50 kA at 415V, 3Ø, 50 Hz as per IS/IEC 60947-4-1 standard



SCPD Type	Contactor Type	Relay Type
DN MCCB	MNX	MN
		

Sr. No.	Ratings at 3Ø, 415V, 50 Hz				Contactor Type			Overload Relay			MCCB	
	hp	kW	Current, In (A)		Star	Delta	Main	Type	Range (A)		Type	Rating (A)
			Line	Phase								
1	1	0.75	2	1.2	MNX 18	MNX 50	MNX 50	REO 1.1	0.6	3	DN0-100M	32
2	1.5	1.1	2.7	1.6	MNX 18	MNX 50	MNX 50	REO 1.1	0.6	3	DN0-100M	32
3	1.75	1.3	3	1.7	MNX 18	MNX 50	MNX 50	REO 1.1	0.6	3	DN0-100M	32
4	2	1.5	3.5	2.0	MNX 18	MNX 50	MNX 50	REO 1.1	0.6	3	DN0-100M	32
5	3	2.2	4.9	2.8	MNX 18	MNX 50	MNX 50	REO 1.1	2.4	12	DN0-100M	32
6	4	3	6	3.5	MNX 18	MNX 50	MNX 50	REO 1.1	2.4	12	DN0-100M	32
7	5	3.7	7.5	4.3	MNX 18	MNX 50	MNX 50	REO 1.1	2.4	12	DN0-100M	32
8	5.5	4	8.5	4.9	MNX 18	MNX 50	MNX 50	REO 1.1	2.4	12	DN0-100M	32
9	7.5	5.5	11	6.4	MNX 18	MNX 50	MNX 50	REO 1.1	2.4	12	DN0-100M	32
10	10	7.5	14.5	8.4	MNX 18	MNX 50	MNX 50	REO 1.1	2.4	12	DN0-100M	32
11	12.5	9.3	17.3	10.0	MNX 25	MNX 50	MNX 50	MN5	9	15	DN0-100M	40
12	15	11	21	12.1	MNX 25	MNX 50	MNX 50	MN5	9	15	DN0-100M	50
13	17.5	13	24	13.9	MNX 25	MNX 50	MNX 50	MN5	9	15	DN0-100M	50
14	20	15	29	16.7	MNX 25	MNX 50	MNX 50	MN5	14	23	DN0-100M	63
15	25	18.5	35	20.2	MNX 50	MNX 80	MNX 80	MN5	14	23	DN0-100M	80
16	30	22	40	23.1	MNX 50	MNX 80	MNX 80	MN5	20	33	DN0-100M	100
17	40	30	54	31.2	MNX 50	MNX 95	MNX 95	MN12	28	46.5	DN1-160M	100
18	50	37	68	39.3	MNX 50	MNX 95	MNX 95	MN12	28	46.5	DN1-160M	125
19	60	45	81	46.8	MNX 70	MNX 95	MNX 95	MN12	42	69	DN1-160M	160
20	75	55	94	54.3	MNX 70	MNX 95	MNX 95	MN12	42	69	DN2-250M	200
21	100	75	130	75.1	MNX 80	MNX 140	MNX 140	MN12	60	100	DN2-250M	250
22	110	80	139	80.3	MNX 95	MNX 250	MNX 250	MN12	60	100	DN3-400M	320
23	120	90	157	90.6	MNX 95	MNX 250	MNX 250	MN12	90	150	DN3-400M	320
24	150	110	189	109	MNX 110	MNX 250	MNX 250	MN12	90	150	DN3-400M	400
25	170	125	207	120	MNX 140	MNX 250	MNX 250	MN12	90	150	DN3-400M	400
26	180	132	226	130	MNX 140	MNX 300	MNX 300	MN12	90	150	DN3-630M	500
27	200	150	248	143	MNX 185	MNX 300	MNX 300	MN12	135	225	DN3-630M	500
28	215	160	270	156	MNX 185	MNX 300	MNX 300	MN12	135	225	DN3-630M	630
29	240	180	298	172	MNX 185	MNX 300	MNX 300	MN12	135	225	DN3-630M	630
30	270	200	336	194	MNX 225	MNX 300	MNX 300	MN12	135	225	DN3-630M	630
31	300	225	360	207.9	MNX 650	MNX 650	MNX 650	MN12	180	300	DN4-1250S (MTX 1.0 MCCB)	1250
32	335	250	420	242.5	MNX 650	MNX 650	MNX 650	MN12	180	300	DN4-1250S (MTX 1.0 MCCB)	1250
33	370	275	440	254	MNX 650	MNX 650	MNX 650	MN12	180	300	DN4-1250S (MTX 1.0 MCCB)	1250

Separate mounting kit required for REO 1.1

## Fuseless Protection for Star Delta Starter Feeders : IE2 Motors

TYPE '2' Co-ordination, Iq=50 kA at 415V, 3Ø, 50 Hz as per IS/IEC 60947-4-1 standard

SCPD Type	Contactor Type	Relay Type
DN MCCB	MNX	REO
		

Sr. No.	Ratings at 3Ø, 415V, 50 Hz				Contactor Type			Overload Relay			MCCB	
	hp	kW	Current, In (A)		Star	Delta	Main	Type	Range (A)		Type	Rating (A)
			Line	Phase								
1	1	0.75	2	1.2	MNX 18	MNX 50	MNX 50	REO 1.1	0.6	3	DN0-100M	32
2	1.5	1.1	2.7	1.6	MNX 18	MNX 50	MNX 50	REO 1.1	0.6	3	DN0-100M	32
3	1.75	1.3	3	1.7	MNX 18	MNX 50	MNX 50	REO 1.1	0.6	3	DN0-100M	32
4	2	1.5	3.5	2.0	MNX 18	MNX 50	MNX 50	REO 1.1	0.6	3	DN0-100M	32
5	3	2.2	4.9	2.8	MNX 18	MNX 50	MNX 50	REO 1.1	2.4	12	DN0-100M	32
6	4	3	6	3.5	MNX 18	MNX 50	MNX 50	REO 1.1	2.4	12	DN0-100M	32
7	5	3.7	7.5	4.3	MNX 18	MNX 50	MNX 50	REO 1.1	2.4	12	DN0-100M	32
8	5.5	4	8.5	4.9	MNX 18	MNX 50	MNX 50	REO 1.1	2.4	12	DN0-100M	32
9	7.5	5.5	11	6.4	MNX 18	MNX 50	MNX 50	REO 1.1	2.4	12	DN0-100M	32
10	10	7.5	14.5	8.4	MNX 18	MNX 50	MNX 50	REO 1.1	2.4	12	DN0-100M	32
11	12.5	9.3	17.3	10.0	MNX 25	MNX 50	MNX 50	REO 1.1	2.4	12	DN0-100M	40
12	15	11	21	12.1	MNX 25	MNX 50	MNX 50	REO 1.1	9	45	DN0-100M	50
13	17.5	13	24	13.9	MNX 25	MNX 50	MNX 50	REO 1.1	9	45	DN0-100M	50
14	20	15	29	16.7	MNX 25	MNX 50	MNX 50	REO 1.1	9	45	DN0-100M	63
15	25	18.5	35	20.2	MNX 50	MNX 80	MNX 80	REO 1.1	9	45	DN0-100M	80
16	30	22	40	23.1	MNX 50	MNX 80	MNX 80	REO 1.1	9	45	DN0-100M	100
17	40	30	54	31.2	MNX 50	MNX 95	MNX 95	REO 1.1	9	45	DN1-160M	100
18	50	37	68	39.3	MNX 50	MNX 95	MNX 95	REO 1.1	9	45	DN1-160M	125
19	60	45	81	46.8	MNX 70	MNX 95	MNX 95	REO 4	18	90	DN1-160M	160
20	75	55	94	54.3	MNX 70	MNX 95	MNX 95	REO 4	18	90	DN2-250M	200
21	100	75	130	75.1	MNX 80	MNX 140	MNX 140	REO 4	18	90	DN2-250M	250
22	110	80	139	80.3	MNX 95	MNX 250	MNX 250	REO 4	18	90	DN3-400M	320
23	120	90	157	90.6	MNX 95	MNX 250	MNX 250	REO 4	72	360	DN3-400M	320
24	150	110	189	109	MNX 110	MNX 250	MNX 250	REO 4	72	360	DN3-400M	400
25	170	125	207	120	MNX 140	MNX 250	MNX 250	REO 4	72	360	DN3-400M	400
26	180	132	226	130	MNX 140	MNX 300	MNX 300	REO 4	72	360	DN3-630M	500
27	200	150	248	143	MNX 185	MNX 300	MNX 300	REO 4	72	360	DN3-630M	500
28	215	160	270	156	MNX 185	MNX 300	MNX 300	REO 4	72	360	DN3-630M	630
29	240	180	298	172	MNX 185	MNX 300	MNX 300	REO 4	72	360	DN3-630M	630
30	270	200	336	194	MNX 225	MNX 300	MNX 300	REO 4	72	360	DN3-630M	630
31	300	225	360	207.9	MNX 650	MNX 650	MNX 650	REO 4	72	360	DN4-1250S (MTX 1.0 MCCB)	1250
32	335	250	420	242.5	MNX 650	MNX 650	MNX 650	REO 4	72	360	DN4-1250S (MTX 1.0 MCCB)	1250
33	370	275	440	254	MNX 650	MNX 650	MNX 650	REO 4	72	360	DN4-1250S (MTX 1.0 MCCB)	1250

Separate mounting kit required for REO 1.1

## Fuseless Protection for Star Delta Starter Feeders : IE2 Motors

TYPE '2' Co-ordination, I<sub>q</sub>=50 kA at 415V, 3Ø, 50 Hz as per IS/IEC 60947-4-1 standard

SCPD Type	Contactor Type	Relay Type
DN MCCB	MO	RTO
		

Sr. No.	Motor Ratings at 3Ø, 415V, 50 Hz				Contactor Type			Overload Relay			MCCB	
	hp	kW	Current, In (A)		Star	Delta	Main	Type	Range (A)		Type	Rating (In)
			Line	Phase								
1	1	0.75	2	1.2	MO 18	MO 50	MO 50	REO 1.1	0.6	3	DN0-100M	32
2	1.5	1.1	2.7	1.6	MO 18	MO 50	MO 50	REO 1.1	0.6	3	DN0-100M	32
3	1.75	1.3	3	1.7	MO 18	MO 50	MO 50	REO 1.1	0.6	3	DN0-100M	32
4	2	1.5	3.5	2.0	MO 18	MO 50	MO 50	REO 1.1	0.6	3	DN0-100M	32
5	3	2.2	4.9	2.8	MO 18	MO 50	MO 50	REO 1.1	2.4	12	DN0-100M	32
6	4	3	6	3.5	MO 18	MO 50	MO 50	REO 1.1	2.4	12	DN0-100M	32
7	5	3.7	7.5	4.3	MO 18	MO 50	MO 50	REO 1.1	2.4	12	DN0-100M	32
8	5.5	4	8.5	4.9	MO 18	MO 50	MO 50	REO 1.1	2.4	12	DN0-100M	32
9	7.5	5.5	11	6.4	MO 18	MO 50	MO 50	REO 1.1	2.4	12	DN0-100M	32
10	10	7.5	14.5	8.4	MO 18	MO 50	MO 50	REO 1.1	2.4	12	DN0-100M	32
11	12.5	9.3	17.3	10.0	MO 25	MO 50	MO 50	RTO-2	6.7	9.7	DN0-100M	40
12	15	11	21	12.1	MO 25	MO 50	MO 50	RTO-2	10.5	16	DN0-100M	50
13	17.5	13	24	13.9	MO 25	MO 50	MO 50	RTO-2	10.5	16	DN0-100M	50
14	20	15	29	16.7	MO 25	MO 50	MO 50	RTO-2	15	21	DN0-100M	63
15	25	18.5	35	20.2	MO 32	MO 70	MO 70	RTO-2	15	21	DN0-100M	80
16	30	22	40	23.1	MO 50	MO 70	MO 70	RTO-2	20	31	DN0-100M	100
17	40	30	54	31.2	MO 50	MO 95	MO 95	RTO-3	29	38	DN1-160M	100
18	50	37	68	39.3	MO 50	MO 95	MO 95	RTO-3	37	49	DN1-160M	125
19	60	45	81	46.8	MO 70	MO 95	MO 95	RTO-3	37	49	DN1-160M	160
20	75	55	94	54.3	MO 70	MO 95	MO 95	RTO-3	47	62	DN2-250M	200
21	100	75	130	75.1	MO 80	MO 140	MO 140	RTO-4	57	84	DN2-250M	250
22	110	80	139	80.3	MO 95	MO 250	MO 250	RTO-4	57	84	DN3-400M	320
23	120	90	157	90.6	MO 95	MO 250	MO 250	RTO-4	72	108	DN3-400M	320
24	150	110	189	109	MO 110	MO 250	MO 250	RTO-4	105	156	DN3-400M	400
25	170	125	207	120	MO 140	MO 250	MO 250	RTO-4	105	156	DN3-400M	400
26	180	132	226	131	MO 140	MO 300	MO 300	RTO-4	105	156	DN3-630M	500
27	200	150	248	143	MO 185	MO 300	MO 300	RTO-4	105	156	DN3-630M	500

Separate mounting kit required for REO 1.1

## Fuseless Protection for Star Delta Starter Feeders : IE2 Motors

TYPE '2' Co-ordination,  $I_q=50$  kA at 415V, 3 $\phi$ , 50 Hz as per IS/IEC 60947-4-1 standard

SCPD Type	Contactor Type	Relay Type
DN MCCB	MO	REO
		

Sr. No.	Motor Ratings at 3 $\phi$ , 415V, 50 Hz				Contactor Type			Overload Relay			MCCB	
	hp	kW	Current, In (A)		Star	Delta	Main	Type	Range (A)		Type	Rating (In)
			Line	Phase								
1	1	0.75	2	1.2	MO 18	MO 50	MO 50	REO 1.1	0.6	3	DN0-100M	32
2	1.5	1.1	2.7	1.6	MO 18	MO 50	MO 50	REO 1.1	0.6	3	DN0-100M	32
3	1.75	1.3	3	1.7	MO 18	MO 50	MO 50	REO 1.1	0.6	3	DN0-100M	32
4	2	1.5	3.5	2.0	MO 18	MO 50	MO 50	REO 1.1	0.6	3	DN0-100M	32
5	3	2.2	4.9	2.8	MO 18	MO 50	MO 50	REO 1.1	2.4	12	DN0-100M	32
6	4	3	6	3.5	MO 18	MO 50	MO 50	REO 1.1	2.4	12	DN0-100M	32
7	5	3.7	7.5	4.3	MO 18	MO 50	MO 50	REO 1.1	2.4	12	DN0-100M	32
8	5.5	4	8.5	4.9	MO 18	MO 50	MO 50	REO 1.1	2.4	12	DN0-100M	32
9	7.5	5.5	11	6.4	MO 18	MO 50	MO 50	REO 1.1	2.4	12	DN0-100M	32
10	10	7.5	14.5	8.4	MO 18	MO 50	MO 50	REO 1.1	2.4	12	DN0-100M	32
11	12.5	9.3	17.3	10.0	MO 25	MO 50	MO 50	REO 1.1	2.4	12	DN0-100M	40
12	15	11	21	12.1	MO 25	MO 50	MO 50	REO 1.1	9	45	DN0-100M	50
13	17.5	13	24	13.9	MO 25	MO 50	MO 50	REO 1.1	9	45	DN0-100M	50
14	20	15	29	16.7	MO 25	MO 50	MO 50	REO 1.1	9	45	DN0-100M	63
15	25	18.5	35	20.2	MO 32	MO 70	MO 70	REO 1.1	9	45	DN0-100M	80
16	30	22	40	23.1	MO 50	MO 70	MO 70	REO 1.1	9	45	DN0-100M	100
17	40	30	54	31.2	MO 50	MO 95	MO 95	REO 1.1	9	45	DN1-160M	100
18	50	37	68	39.3	MO 50	MO 95	MO 95	REO 1.1	9	45	DN1-160M	125
19	60	45	81	46.8	MO 70	MO 95	MO 95	REO 4	18	90	DN1-160M	160
20	75	55	94	54.3	MO 70	MO 95	MO 95	REO 4	18	90	DN2-250M	200
21	100	75	130	75.1	MO 80	MO 140	MO 140	REO 4	18	90	DN2-250M	250
22	110	80	139	80.3	MO 95	MO 250	MO 250	REO 4	18	90	DN3-400M	320
23	120	90	157	90.6	MO 95	MO 250	MO 250	REO 4	72	360	DN3-400M	320
24	150	110	189	109	MO 110	MO 250	MO 250	REO 4	72	360	DN3-400M	400
25	170	125	207	120	MO 140	MO 250	MO 250	REO 4	72	360	DN3-400M	400
26	180	132	226	131	MO 140	MO 300	MO 300	REO 4	72	360	DN3-630M	500
27	200	150	248	143	MO 185	MO 300	MO 300	REO 4	72	360	DN3-630M	500

Separate mounting kit required for REO 1.1



## Fuseless Protection for Star Delta Starter Feeders : IE2 Motors



TYPE '2' Co-ordination,  $I_q=50$  kA at 415V, 3 $\phi$ , 50 Hz as per IS/IEC 60947-4-1 standard

SCPD Type	Contactor Type	Relay Type
MOG MPCB	MNX	MN
		

Sr. No.	Ratings at 3 $\phi$ , 415V, 50 Hz				Contactor Type			Overload Relay		MPCB	
	hp	kW	Current, In (A)		Star	Delta	Main	Type	Range (A)	Type	Rating (A)
			Line	Phase							
1	0.33	0.25	0.8	0.5	MNX 9	MNX 9	MNX 9	MN2	0.45 - 0.75	MOG-H1M	1.6
2	0.5	0.37	1.2	0.7	MNX 9	MNX 9	MNX 9	MN2	0.6 - 1	MOG-H1M	2.5
3	0.75	0.55	1.5	0.9	MNX 9	MNX 9	MNX 9	MN2	0.9 - 1.5	MOG-H1M	2.5
4	1	0.75	2.0	1.2	MNX 9	MNX 18	MNX 18	MN2	0.9 - 1.5	MOG-H1M	4
5	1.5	1.1	2.7	1.6	MNX 9	MNX 18	MNX 18	MN2	1.4 - 2.3	MOG-H1M	4
6	1.75	1.3	3.0	1.7	MNX 9	MNX 22	MNX 22	MN2	1.4 - 2.3	MOG-H1M	6.3
7	2	1.5	3.5	2.0	MNX 9	MNX 22	MNX 22	MN2	2.0 - 3.3	MOG-H1M	6.3
8	3	2.2	4.9	2.8	MNX 9	MNX 25	MNX 25	MN2	2.0 - 3.3	MOG-H1M	10
9	4	3	6.0	3.5	MNX 9	MNX 25	MNX 25	MN2	3.0 - 5.0	MOG-H1M	10
10	5	3.7	7.5	4.3	MNX 9	MNX 25	MNX 25	MN2	3.0 - 5.0	MOG-H1M	16
11	5.5	4	8.5	4.9	MNX 9	MNX 25	MNX 25	MN2	4.5 - 7.5	MOG-H1M	16
12	7.5	5.5	11.0	6.4	MNX 9	MNX 25	MNX 25	MN2	6 - 10	MOG-H1M	16
13	10	7.5	14.5	8.4	MNX 18	MNX 40	MNX 40	MN2	6 - 10	MOG-H1M	25
14	12.5	9.3	17.3	10.0	MNX 18	MNX 50	MNX 50	MN5	9 - 15	MOG-H1M	25
15	15	11	21.0	12.1	MNX 18	MNX 50	MNX 50	MN5	9 - 15	MOG-H1M	32
16	17.5	13	24.0	13.9	MNX 18	MNX 70	MNX 70	MN5	14 - 23	MOG-H2M	40
17	20	15	29.0	16.7	MNX 25	MNX 70	MNX 70	MN5	14 - 23	MOG-H2M	50
18	25	18.5	35.0	20.2	MNX 25	MNX 70	MNX 70	MN5	20 - 33	MOG-H2M	50
19	30	22	40.0	23.1	MNX 32	MNX 80	MNX 80	MN5	20 - 33	MOG-H2M	63

## Fuseless Protection for Star Delta Starter Feeders : IE2 Motors

TYPE '2' Co-ordination, Iq=50 kA at 415V, 3Ø, 50 Hz as per IS/IEC 60947-4-1 standard

SCPD Type	Contactor Type	Relay Type
MOG MPCB	MNX	REO
		

Sr. No.	Ratings at 3Ø, 415V, 50 Hz				Contactor Type			Overload Relay		MPCB	
	hp	kW	Current, In (A)		Star	Delta	Main	Type	Range (A)	Type	Rating (A)
			Line	Phase							
1	0.33	0.25	0.8	0.5	MNX 9	MNX 9	MNX 9	REO 1.1	0.15- 0.75	MOG-H1M	1.6
2	0.5	0.37	1.2	0.7	MNX 9	MNX 9	MNX 9	REO 1.1	0.6 - 3	MOG-H1M	2.5
3	0.75	0.55	1.5	0.9	MNX 9	MNX 9	MNX 9	REO 1.1	0.6 - 3	MOG-H1M	2.5
4	1	0.75	2.0	1.2	MNX 9	MNX 18	MNX 18	REO 1.1	0.6 - 3	MOG-H1M	4
5	1.5	1.1	2.7	1.6	MNX 9	MNX 18	MNX 18	REO 1.1	0.6 - 3	MOG-H1M	4
6	1.75	1.3	3.0	1.7	MNX 9	MNX 22	MNX 22	REO 1.1	0.6 - 3	MOG-H1M	6.3
7	2	1.5	3.5	2.0	MNX 9	MNX 22	MNX 22	REO 1.1	0.6 - 3	MOG-H1M	6.3
8	3	2.2	4.9	2.8	MNX 9	MNX 25	MNX 25	REO 1.1	2.4 - 12	MOG-H1M	10
9	4	3	6.0	3.5	MNX 9	MNX 25	MNX 25	REO 1.1	2.4 - 12	MOG-H1M	10
10	5	3.7	7.5	4.3	MNX 9	MNX 25	MNX 25	REO 1.1	2.4 - 12	MOG-H1M	16
11	5.5	4	8.5	4.9	MNX 9	MNX 25	MNX 25	REO 1.1	2.4 - 12	MOG-H1M	16
12	7.5	5.5	11.0	6.4	MNX 9	MNX 25	MNX 25	REO 1.1	2.4 - 12	MOG-H1M	16
13	10	7.5	14.5	8.4	MNX 18	MNX 40	MNX 40	REO 1.1	2.4 - 12	MOG-H1M	25
14	12.5	9.3	17.3	10.0	MNX 18	MNX 50	MNX 50	REO 1.1	2.4 - 12	MOG-H1M	25
15	15	11	21.0	12.1	MNX 18	MNX 50	MNX 50	REO 1.1	9 - 45	MOG-H1M	32
16	17.5	13	24.0	13.9	MNX 18	MNX 70	MNX 70	REO 1.1	9 - 45	MOG-H2M	40
17	20	15	29.0	16.7	MNX 25	MNX 70	MNX 70	REO 1.1	9 - 45	MOG-H2M	50
18	25	18.5	35.0	20.2	MNX 25	MNX 70	MNX 70	REO 1.1	9 - 45	MOG-H2M	50
19	30	22	40.0	23.1	MNX 32	MNX 80	MNX 80	REO 1.1	9 - 45	MOG-H2M	63

Separate mounting kit required

## Fuseless Protection for Star Delta Starter Feeders : IE2 Motors

TYPE '2' Co-ordination, I<sub>q</sub>=50 kA at 415V, 3Ø, 50 Hz as per IS/IEC 60947-4-1 standard

SCPD Type	Contactor Type	Relay Type
MOG MPCB	MO	RTO
		

Sr. No.	Motor Ratings at 3Ø, 415V, 50 Hz				Contactor Type			Overload Relay		MPCB	
	hp	kW	I line (A)	I phase (A)	Star	Delta	Main	Type	Range (A)	Type	Rating (A)
1	0.33	0.25	0.8	0.5	MO 9	MO 9	MO 9	RTO1	0.31 - 0.55	MOG-H1M	1.6
2	0.5	0.37	1.2	0.7	MO 9	MO 9	MO 9	RTO1	0.55 - 0.85	MOG-H1M	2.5
3	0.75	0.55	1.5	0.9	MO 9	MO 9	MO 9	RTO1	0.78 - 1.2	MOG-H1M	2.5
4	1	0.75	2.0	1.2	MO 9	MO 12	MO 12	RTO1	1.2 - 2	MOG-H1M	4
5	1.5	1.1	2.7	1.6	MO 9	MO 12	MO 12	RTO1	1.2 - 2	MOG-H1M	4
6	1.75	1.3	3.0	1.7	MO 9	MO 18	MO 18	RTO1	1.2 - 2	MOG-H1M	6.3
7	2	1.5	3.5	2.0	MO 9	MO 18	MO 18	RTO1	1.9 - 2.8	MOG-H1M	6.3
8	3	2.2	4.9	2.8	MO 9	MO 25	MO 25	RTO1	2.4 - 3.6	MOG-H1M	10
9	4	3	6.0	3.5	MO 9	MO 25	MO 25	RTO1	2.4 - 3.6	MOG-H1M	10
10	5	3.7	7.5	4.3	MO 9	MO 25	MO 25	RTO1	3.5 - 5.2	MOG-H1M	16
11	5.5	4	8.5	4.9	MO 9	MO 25	MO 25	RTO1	3.5 - 5.2	MOG-H1M	16
12	7.5	5.5	11.0	6.4	MO 9	MO 25	MO 25	RTO1	4.6 - 6.7	MOG-H1M	16
13	10	7.5	14.5	8.4	MO 18	MO 32	MO 32	RTO1	6.7 - 9.7	MOG-H1M	25
14	12.5	9.3	17.3	10.0	MO 18	MO 32	MO 32	RTO1	8.5 - 12.5	MOG-H1M	25
15	15	11	21.0	12.1	MO 18	MO 45	MO 45	RTO1	8.5 - 12.5	MOG-H1M	32
16	17.5	13	24.0	13.9	MO 18	MO 50	MO 50	RTO2	10.5 - 16	MOG-H2M	40
17	20	15	29.0	16.7	MO 25	MO 60	MO 60	RTO2	15 - 21	MOG-H2M	50
18	25	18.5	35.0	20.2	MO 25	MO 60	MO 60	RTO2	15 - 21	MOG-H2M	50
19	30	22	40.0	23.1	MO 32	MO 70	MO 70	RTO2	20 -31	MOG-H2M	63

## Fuseless Protection for Star Delta Starter Feeders : IE2 Motors

TYPE '2' Co-ordination, I<sub>q</sub>=50 kA at 415V, 3Ø, 50 Hz as per IS/IEC 60947-4-1 standard



SCPD Type	Contactor Type	Relay Type
MOG MPCB	MO	REO
		

Sr. No.	Motor Ratings at 3Ø, 415V, 50 Hz				Contactor Type			Overload Relay		MPCB	
	hp	kW	I line (A)	I phase (A)	Star	Delta	Main	Type	Range (A)	Type	Rating (A)
1	0.33	0.25	0.8	0.5	MO 9	MO 9	MO 9	REO 1.1	0.15 – 0.75	MOG-H1M	1.6
2	0.5	0.37	1.2	0.7	MO 9	MO 9	MO 9	REO 1.1	0.6 - 3	MOG-H1M	2.5
3	0.75	0.55	1.5	0.9	MO 9	MO 9	MO 9	REO 1.1	0.6 - 3	MOG-H1M	2.5
4	1	0.75	2.0	1.2	MO 9	MO 12	MO 12	REO 1.1	0.6 - 3	MOG-H1M	4
5	1.5	1.1	2.7	1.6	MO 9	MO 12	MO 12	REO 1.1	0.6 - 3	MOG-H1M	4
6	1.75	1.3	3.0	1.7	MO 9	MO 18	MO 18	REO 1.1	0.6 - 3	MOG-H1M	6.3
7	2	1.5	3.5	2.0	MO 9	MO 18	MO 18	REO 1.1	0.6 - 3	MOG-H1M	6.3
8	3	2.2	4.9	2.8	MO 9	MO 25	MO 25	REO 1.1	2.4 - 12	MOG-H1M	10
9	4	3	6.0	3.5	MO 9	MO 25	MO 25	REO 1.1	2.4 - 12	MOG-H1M	10
10	5	3.7	7.5	4.3	MO 9	MO 25	MO 25	REO 1.1	2.4 - 12	MOG-H1M	16
11	5.5	4	8.5	4.9	MO 9	MO 25	MO 25	REO 1.1	2.4 - 12	MOG-H1M	16
12	7.5	5.5	11.0	6.4	MO 9	MO 25	MO 25	REO 1.1	2.4 - 12	MOG-H1M	16
13	10	7.5	14.5	8.4	MO 18	MO 32	MO 32	REO 1.1	2.4 - 12	MOG-H1M	25
14	12.5	9.3	17.3	10.0	MO 18	MO 32	MO 32	REO 1.1	2.4 - 12	MOG-H1M	25
15	15	11	21.0	12.1	MO 18	MO 45	MO 45	REO 1.1	9 - 45	MOG-H1M	32
16	17.5	13	24.0	13.9	MO 18	MO 50	MO 50	REO 1.1*	9 - 45	MOG-H2M	40
17	20	15	29.0	16.7	MO 25	MO 60	MO 60	REO 1.1*	9 - 45	MOG-H2M	50
18	25	18.5	35.0	20.2	MO 25	MO 60	MO 60	REO 1.1*	9 - 45	MOG-H2M	50
19	30	22	40.0	23.1	MO 32	MO 70	MO 70	REO 1.1*	9 - 45	MOG-H2M	63

\* Separate mounting kit required

## Fuseless Protection for DOL Starter Feeders : IE3 Motors

TYPE '2' Co-ordination, I<sub>q</sub>=50 kA at 415V, 3Ø, 50 Hz as per IS/IEC 60947-4-1 standard



SCPD Type	Contactor Type	Relay Type
DN MCCB	MNX	MN
		

Sr. No.	Motor: 3Ø, 415V, 50 Hz			Contactor Type	Overload Relay			MCCB	
	hp	kW	FLC, In (A)		Type	Range (A)		Type	Rating (A)
1	0.5	0.37	1.2	MNX 50	REO 1.1	0.6	3	DN0-100M	32
2	0.75	0.55	1.5	MNX 50	REO 1.1	0.6	3	DN0-100M	32
3	1	0.75	2	MNX 50	REO 1.1	0.6	3	DN0-100M	32
4	1.5	1.1	2.7	MNX 50	REO 1.1	2.4	12	DN0-100M	32
5	1.75	1.3	3	MNX 50	REO 1.1	2.4	12	DN0-100M	32
6	2	1.5	3.5	MNX 50	REO 1.1	2.4	12	DN0-100M	32
7	3	2.2	4.9	MNX 50	REO 1.1	2.4	12	DN0-100M	32
8	4	3	6	MNX 50	REO 1.1	2.4	12	DN0-100M	32
9	5	3.7	7.5	MNX 50	REO 1.1	2.4	12	DN0-100M	32
10	5.5	4	8.5	MNX 50	REO 1.1	2.4	12	DN0-100M	32
11	7.5	5.5	11	MNX 50	REO 1.1	9	45	DN0-100M	32
12	10	7.5	14.5	MNX 50	REO 1.1	9	45	DN0-100M	32
13	12.5	9.3	17.3	MNX 50	MN5	14	23.0	DN0-100M	32
14	15	11	21	MNX 50	MN5	20	33	DN0-100M	40
15	17.5	13	24	MNX 70	MN5	20	33.0	DN0-100M	50
16	20	15	29	MNX 70	MN5	20	33	DN0-100M	63
17	25	18.5	35	MNX 70	MN5	30	50	DN0-100M	63
18	30	22	40	MNX 80	MN5	30	50	DN0-100M	80
19	40	30	54	MNX 95	MN5	45	75	DN0-100M	100
20	50	37	68	MNX 95	MN5	66	110	DN1-160M	125
21	60	45	81	MNX 140	MN5	66	110	DN1-160M	160
22	75	55	94	MNX 140	MN5	66	110	DN1-160M	160
23	100	75	130	MNX 225	MN12	90	150	DN2-250M	250
24	110	80	139	MNX 225	MN12	90	150	DN2-250M	250
25	120	90	157	MNX 250	MN12	135	225	DN3-400M	320
26	150	110	189	MNX 250	MN12	135	225	DN3-400M	320
27	170	125	207	MNX 300	MN12	180	300	DN3-400M	400
28	180	132	226	MNX 300	MN12	180	300	DN3-400M	400
29	200	150	248	MNX 300	MN12	180	300	DN3-400M	400
30	215	160	270	MNX 400	MN12	180	300	DN3-630M	500
31	240	180	298	MNX 400	MN12	270	450	DN3-630M	500
32	270	200	336	MNX 550	MN12	270	450	DN3-630M	630
33	300	225	360	MNX 550	MN12	270	450	DN3-630M	630

Separate mounting kit required for REO 1.1

## Fuseless Protection for DOL Starter Feeders : IE3 Motors

TYPE '2' Co-ordination,  $I_q=50$  kA at 415V, 3 $\phi$ , 50 Hz as per IS/IEC 60947-4-1 standard

SCPD Type	Contactor Type	Relay Type
DN MCCB	MNX	REO
		

Sr. No.	Motor: 3 $\phi$ , 415V, 50 Hz			Contactor Type	Overload Relay			MCCB	
	hp	kW	FLC, In (A)		Type	Range (A)		Type	Rating (A)
1	0.5	0.37	1.2	MNX 50	REO 1.1	0.6	3	DN0-100M	32
2	0.75	0.55	1.5	MNX 50	REO 1.1	0.6	3	DN0-100M	32
3	1	0.75	2	MNX 50	REO 1.1	0.6	3	DN0-100M	32
4	1.5	1.1	2.7	MNX 50	REO 1.1	2.4	12	DN0-100M	32
5	1.75	1.3	3	MNX 50	REO 1.1	2.4	12	DN0-100M	32
6	2	1.5	3.5	MNX 50	REO 1.1	2.4	12	DN0-100M	32
7	3	2.2	4.9	MNX 50	REO 1.1	2.4	12	DN0-100M	32
8	4	3	6	MNX 50	REO 1.1	2.4	12	DN0-100M	32
9	5	3.7	7.5	MNX 50	REO 1.1	2.4	12	DN0-100M	32
10	5.5	4	8.5	MNX 50	REO 1.1	2.4	12	DN0-100M	32
11	7.5	5.5	11	MNX 50	REO 1.1	9	45	DN0-100M	32
12	10	7.5	14.5	MNX 50	REO 1.1	9	45	DN0-100M	32
13	12.5	9.3	17.3	MNX 50	REO 1.1	9	45	DN0-100M	32
14	15	11	21	MNX 50	REO 1.1	9	45	DN0-100M	40
15	17.5	13	24	MNX 70	REO 1.1	9	45	DN0-100M	50
16	20	15	29	MNX 70	REO 1.1	9	45	DN0-100M	63
17	25	18.5	35	MNX 70	REO 4	9	45	DN0-100M	63
18	30	22	40	MNX 80	REO 4	9	45	DN0-100M	80
19	40	30	54	MNX 95	REO 4	18	90	DN0-100M	100
20	50	37	68	MNX 95	REO 4	18	90	DN1-160M	125
21	60	45	81	MNX 140	REO 4	18	90	DN1-160M	160
22	75	55	94	MNX 140	REO 4	72	360	DN1-160M	160
23	100	75	130	MNX 225	REO 4	72	360	DN2-250M	250
24	110	80	139	MNX 225	REO 4	72	360	DN2-250M	250
25	120	90	157	MNX 250	REO 4	72	360	DN3-400M	320
26	150	110	189	MNX 250	REO 4	72	360	DN3-400M	320
27	170	125	207	MNX 300	REO 4	72	360	DN3-400M	400
28	180	132	226	MNX 300	REO 4	72	360	DN3-400M	400
29	200	150	248	MNX 300	REO 4	72	360	DN3-400M	400
30	215	160	270	MNX 400	REO 4	72	360	DN3-630M	500
31	240	180	298	MNX 400	REO 4	72	360	DN3-630M	500
32	270	200	336	MNX 550	REO 4	72	360	DN3-630M	630
33	300	225	360	MNX 550	REO 4	270	1350	DN3-630M	630

Separate mounting kit required for REO 1.1

## Fuseless Protection for DOL Starter Feeders : IE3 Motors

TYPE '2' Co-ordination,  $I_q=50$  kA at 415V, 3 $\phi$ , 50 Hz as per IS/IEC 60947-4-1 standard

SCPD Type	Contactor Type	Relay Type
DN MCCB	MO	RTO
		

Sr. No.	Motor Ratings at 3 $\phi$ , 415V, 50 Hz			Contactor Type	Overload Relay			MCCB	
	hp	kW	FLC, In (A)		Type	Range (A)		Type	Rating (A)
1	0.5	0.37	1.2	MO 50	REO 1.1	0.6	3	DN0-100M	32
2	0.75	0.55	1.5	MO 50	REO 1.1	0.6	3	DN0-100M	32
3	1	0.75	2	MO 50	REO 1.1	0.6	3	DN0-100M	32
4	1.5	1.1	2.7	MO 50	REO 1.1	2.4	12	DN0-100M	32
5	1.75	1.3	3	MO 50	REO 1.1	2.4	12	DN0-100M	32
6	2	1.5	3.5	MO 50	REO 1.1	2.4	12	DN0-100M	32
7	3	2.2	4.9	MO 50	REO 1.1	2.4	12	DN0-100M	32
8	4	3	6	MO 50	REO 1.1	2.4	12	DN0-100M	32
9	5	3.7	7.5	MO 50	REO 1.1	2.4	12	DN0-100M	32
10	5.5	4	8.5	MO 50	REO 1.1	2.4	12	DN0-100M	32
11	7.5	5.5	11	MO 50	REO 1.1	9	45	DN0-100M	32
12	10	7.5	14.5	MO 50	REO 1.1	9	45	DN0-100M	32
13	12.5	9.3	17.3	MO 50	RTO-2	15	21	DN0-100M	32
14	15	11	21	MO 50	RTO-2	20	31	DN0-100M	40
15	17.5	13	24	MO 50	RTO-2	20	31	DN0-100M	50
16	20	15	29	MO 60	RTO-2	20	31	DN0-100M	63
17	25	18.5	35	MO 60	RTO-2	30	43	DN0-100M	63
18	30	22	40	MO 80	RTO-3	37	49	DN0-100M	80
19	40	30	54	MO 80	RTO-3	47	62	DN0-100M	100
20	50	37	68	MO 110	RTO-3	60	78	DN1-160M	125
21	60	45	81	MO 140	RTO-4	72	108	DN1-160M	160
22	75	55	94	MO 140	RTO-4	72	108	DN1-160M	160
23	100	75	130	MO 185	RTO-4	105	156	DN2-250M	250
24	110	80	139	MO 185	RTO-4	105	156	DN2-250M	250
25	120	90	157	MO 250	RTO-4	138	201	DN3-400M	320
26	150	110	189	MO 250	RTO-4	138	201	DN3-400M	320
27	170	125	207	MO 300	RTO-4	201	291	DN3-400M	400
28	180	132	226	MO 300	RTO-4	201	291	DN3-400M	400
29	200	150	248	MO 300	RTO-4	201	291	DN3-400M	400

Separate mounting kit required for REO 1.1

## Fuseless Protection for DOL Starter Feeders : IE3 Motors

TYPE '2' Co-ordination, Iq=50 kA at 415V, 3Ø, 50 Hz as per IS/IEC 60947-4-1 standard

SCPD Type	Contactor Type	Relay Type
DN MCCB	MO	REO
		



Sr. No.	Motor Ratings at 3Ø, 415V, 50 Hz			Contactor Type	Overload Relay		MCCB		
	hp	kW	FLC, In (A)		Type	Range (A)	Type	Rating (A)	
1	0.5	0.37	1.2	MO 50	REO 1.1	0.6	3	DN0-100M	32
2	0.75	0.55	1.5	MO 50	REO 1.1	0.6	3	DN0-100M	32
3	1	0.75	2	MO 50	REO 1.1	0.6	3	DN0-100M	32
4	1.5	1.1	2.7	MO 50	REO 1.1	2.4	12	DN0-100M	32
5	1.75	1.3	3	MO 50	REO 1.1	2.4	12	DN0-100M	32
6	2	1.5	3.5	MO 50	REO 1.1	2.4	12	DN0-100M	32
7	3	2.2	4.9	MO 50	REO 1.1	2.4	12	DN0-100M	32
8	4	3	6	MO 50	REO 1.1	2.4	12	DN0-100M	32
9	5	3.7	7.5	MO 50	REO 1.1	2.4	12	DN0-100M	32
10	5.5	4	8.5	MO 50	REO 1.1	2.4	12	DN0-100M	32
11	7.5	5.5	11	MO 50	REO 1.1	9	45	DN0-100M	32
12	10	7.5	14.5	MO 50	REO 1.1	9	45	DN0-100M	32
13	12.5	9.3	17.3	MO 50	REO 1.1	9	45	DN0-100M	32
14	15	11	21	MO 50	REO 1.1	9	45	DN0-100M	40
15	17.5	13	24	MO 50	REO 1.1	9	45	DN0-100M	50
16	20	15	29	MO 60	REO 1.1	9	45	DN0-100M	63
17	25	18.5	35	MO 60	REO 1.1	9	45	DN0-100M	63
18	30	22	40	MO 80	REO 1.1	9	45	DN0-100M	80
19	40	30	54	MO 80	REO 4	18	90	DN0-100M	100
20	50	37	68	MO 110	REO 4	18	90	DN1-160M	125
21	60	45	81	MO 140	REO 4	18	90	DN1-160M	160
22	75	55	94	MO 140	REO 4	72	360	DN1-160M	160
23	100	75	130	MO 185	REO 4	72	360	DN2-250M	250
24	110	80	139	MO 185	REO 4	72	360	DN2-250M	250
25	120	90	157	MO 250	REO 4	72	360	DN3-400M	320
26	150	110	189	MO 250	REO 4	72	360	DN3-400M	320
27	170	125	207	MO 300	REO 4	72	360	DN3-400M	400
28	180	132	226	MO 300	REO 4	72	360	DN3-400M	400
29	200	150	248	MO 300	REO 4	72	360	DN3-400M	400

Separate mounting kit required for REO 1.1



## Fuseless Protection for DOL Starter Feeders : IE3 Motors



TYPE '2' Co-ordination, Iq=50 kA at 415V, 3Ø, 50 Hz as per IS/IEC 60947-4-1 standard

SCPD Type	Contactor Type
MOG MPCB	MNX
	

Sr. No.	Motor: 3Ø, 415V, 50 Hz			Contactor Type	MPCB	
	hp	kW	FLC, In (A)		Type	Rating (A)
1	0.16	0.12	0.5	MNX 9	MOG-S1/MOG-H1	0.4 - 0.63
2	0.25	0.18	0.6	MNX 9	MOG-S1/MOG-H1	0.63 - 1
3	0.33	0.25	0.8	MNX 9	MOG-S1/MOG-H1	0.63 - 1
4	0.5	0.37	1.2	MNX 9	MOG-S1/MOG-H1	1 - 1.6
5	0.75	0.55	1.5	MNX 9	MOG-S1/MOG-H1	1 - 1.6
6	1	0.75	2.0	MNX 9	MOG-S1/MOG-H1	1.6 - 2.5
7	1.5	1.1	2.7	MNX 12	MOG-S1/MOG-H1	2.5 - 4
8	1.75	1.3	3.0	MNX 12	MOG-S1/MOG-H1	2.5 - 4
9	2	1.5	3.5	MNX 12	MOG-S1/MOG-H1	2.5 - 4
10	3	2.2	4.9	MNX 22	MOG-S1/MOG-H1	4 - 6.3
11	4	3	6.0	MNX 25	MOG-S1/MOG-H1	4 - 6.3
12	5	3.7	7.5	MNX 25	MOG-S1/MOG-H1	6.3 - 10
13	5.5	4	8.5	MNX 25	MOG-S1/MOG-H1	6.3 - 10
14	7.5	5.5	11.0	MNX 25	MOG-S1/MOG-H1	9 - 13
15	10	7.5	14.5	MNX 25	MOG-S1/MOG-H1	11 - 16
16	15	11	21.0	MNX 40	MOG-S1/MOG-H1	19 - 25
17	17.5	13	24.0	MNX 50	MOG-S1/MOG-H1	24 - 32
18	20	15	29.0	MNX 70	MOG-H2	28 - 40
19	25	18.5	35.0	MNX 70	MOG-H2	35 - 50
20	30	22	40.0	MNX 70	MOG-H2	35 - 50

## Fuseless Protection for DOL Starter Feeders : IE3 Motors



TYPE '2' Co-ordination, Iq=50 kA at 415V, 3Ø, 50 Hz as per IS/IEC 60947-4-1 standard

SCPD Type	Contactor Type
MOG MPCB	MO
	

Sr. No.	Motor Ratings at 3Ø, 415V, 50 Hz			Contactor Type	MPCB	
	hp	kW	FLC, In (A)		Type	Rating (A)
1	0.16	0.12	0.51	MO 9	MOG-S1 / MOG-H1	0.4 - 0.63
2	0.25	0.18	0.6	MO 9	MOG- S1 / MOG-H1	0.63 - 1
3	0.33	0.25	0.8	MO 9	MOG-S1 / MOG-H1	0.63 - 1
4	0.5	0.37	1.2	MO 9	MOG- S1 / MOG-H1	1 - 1.6
5	0.75	0.55	1.5	MO 9	MOG-S1 / MOG-H1	1 - 1.6
6	1	0.75	2.0	MO 9	MOG- S1 / MOG-H1	1.6 - 2.5
7	1.5	1.1	2.7	MO 12	MOG-S1 / MOG-H1	2.5 - 4
8	1.75	1.3	3.0	MO 12	MOG- S1 / MOG-H1	2.5 - 4
9	2	1.5	3.5	MO 12	MOG-S1 / MOG-H1	2.5 - 4
10	3	2.2	4.9	MO 18	MOG- S1 / MOG-H1	4 - 6.3
11	4	3	6.0	MO 25	MOG-S1 / MOG-H1	4 - 6.3
12	5	3.7	7.5	MO 25	MOG- S1 / MOG-H1	6.3 - 10
13	5.5	4	8.5	MO 25	MOG-S1 / MOG-H1	6.3 - 10
14	7.5	5.5	11.0	MO 25	MOG- S1 / MOG-H1	9 - 13
15	10	7.5	14.5	MO 25	MOG- S1 / MOG-H1	11 - 16
16	15.0	11.0	21.0	MO 32	MOG- S1 / MOG-H1	19 - 25
17	17.50	13.00	24.00	MO 32	MOG- S1 / MOG-H1	24 - 32
18	20.00	15.00	29.0	MO 50	MOG - H2	28 - 40
19	25.00	18.50	35.0	MO 50	MOG - H2	35 - 50
20	30.0	22.00	40.0	MO 60	MOG - H2	35 - 50

## Fuseless Protection for Star Delta Starter Feeders : IE3 Motors

TYPE '2' Co-ordination, Iq=50 kA at 415V, 3Ø, 50 Hz as per IS/IEC 60947-4-1 standard

SCPD Type	Contactor Type	Relay Type
DN MCCB	MNX	MN
		

Sr. No.	Ratings at 3Ø, 415V, 50 Hz				Contactor Type			Overload Relay			MCCB	
	hp	kW	Current, In (A)		Star	Delta	Main	Type	Range (A)		Type	Rating (A)
			Line	Phase								
1	1	0.75	2	1.2	MNX 18	MNX 50	MNX 50	REO 1.1	0.6	3	DN0-100M	32
2	1.5	1.1	2.7	1.6	MNX 18	MNX 50	MNX 50	REO 1.1	0.6	3	DN0-100M	32
3	1.75	1.3	3	1.7	MNX 18	MNX 50	MNX 50	REO 1.1	0.6	3	DN0-100M	32
4	2	1.5	3.5	2.0	MNX 18	MNX 50	MNX 50	REO 1.1	0.6	3	DN0-100M	32
5	3	2.2	4.9	2.8	MNX 18	MNX 50	MNX 50	REO 1.1	2.4	12	DN0-100M	32
6	4	3	6	3.5	MNX 18	MNX 50	MNX 50	REO 1.1	2.4	12	DN0-100M	32
7	5	3.7	7.5	4.3	MNX 18	MNX 50	MNX 50	REO 1.1	2.4	12	DN0-100M	32
8	5.5	4	8.5	4.9	MNX 18	MNX 50	MNX 50	MN2	4.5	7.5	DN0-100M	32
9	7.5	5.5	11	6.4	MNX 18	MNX 50	MNX 50	MN2	4.5	7.5	DN0-100M	32
10	10	7.5	14.5	8.4	MNX 18	MNX 50	MNX 50	MN2	6	10	DN0-100M	40
11	12.5	9.3	17.3	10.0	MNX 25	MNX 50	MNX 50	MN5	9	15	DN0-100M	40
12	15	11	21	12.1	MNX 25	MNX 50	MNX 50	MN5	9	15	DN0-100M	50
13	17.5	13	24	13.9	MNX 25	MNX 50	MNX 50	MN5	9	15	DN0-100M	63
14	20	15	29	16.7	MNX 25	MNX 80	MNX 80	MN5	14	23	DN0-100M	80
15	25	18.5	35	20.2	MNX 50	MNX 80	MNX 80	MN5	14	23	DN0-100M	80
16	30	22	40	23.1	MNX 50	MNX 80	MNX 80	MN5	20	33	DN0-100M	100
17	40	30	54	31.2	MNX 50	MNX 95	MNX 95	MN12	28	46.5	DN1-160M	125
18	50	37	68	39.3	MNX 50	MNX 95	MNX 95	MN12	28	46.5	DN1-160M	160
19	60	45	81	46.8	MNX 70	MNX 95	MNX 95	MN12	42	69	DN2-250M	200
20	75	55	94	54.3	MNX 70	MNX 95	MNX 95	MN12	42	69	DN2-250M	200
21	100	75	130	75.1	MNX 80	MNX 250	MNX 250	MN12	60	100	DN3-400M	320
22	110	80	139	80.3	MNX 95	MNX 250	MNX 250	MN12	60	100	DN3-400M	320
23	120	90	157	90.6	MNX 95	MNX 250	MNX 250	MN12	60	100	DN3-400M	320
24	150	110	189	109	MNX 110	MNX 250	MNX 250	MN12	90	150	DN3-400M	400
25	170	125	207	120	MNX 140	MNX 300	MNX 300	MN12	90	150	DN3-630M	500
26	180	132	226	131	MNX 140	MNX 300	MNX 300	MN12	90	150	DN3-630M	500
27	200	150	248	143	MNX 185	MNX 300	MNX 300	MN12	135	225	DN3-630M	500
28	215	160	270	156	MNX 185	MNX 300	MNX 300	MN12	135	225	DN3-630M	630
29	240	180	29	172	MNX 185	MNX 300	MNX 300	MN12	135	225	DN3-630M	630
30	270	200	336	194	MNX 650	MNX 650	MNX 650	MN12	180	300	DN4-1250S (MTX 1.0 MCCB)	1250
31	300	225	360	207.9	MNX 650	MNX 650	MNX 650	MN12	180	300	DN4-1250S (MTX 1.0 MCCB)	1250
32	335	250	420	242.5	MNX 650	MNX 650	MNX 650	MN12	180	300	DN4-1250S (MTX 1.0 MCCB)	1250
33	370	275	440	254	MNX 650	MNX 650	MNX 650	MN12	180	300	DN4-1250S (MTX 1.0 MCCB)	1250

Separate mounting kit required for REO 1.1

## Fuseless Protection for Star Delta Starter Feeders : IE3 Motors

TYPE '2' Co-ordination, Iq=50 kA at 415V, 3Ø, 50 Hz as per IS/IEC 60947-4-1 standard

SCPD Type	Contactor Type	Relay Type
DN MCCB	MNX	REO
		

Sr. No.	Ratings at 3Ø, 415V, 50 Hz				Contactor Type			Overload Relay			MCCB	
	hp	kW	Current, In (A)		Star	Delta	Main	Type	Range (A)		Type	Rating (A)
			Line	Phase								
1	1	0.75	2	1.2	MNX 18	MNX 50	MNX 50	REO 1.1	0.6	3	DN0-100M	32
2	1.5	1.1	2.7	1.6	MNX 18	MNX 50	MNX 50	REO 1.1	0.6	3	DN0-100M	32
3	1.75	1.3	3	1.7	MNX 18	MNX 50	MNX 50	REO 1.1	0.6	3	DN0-100M	32
4	2	1.5	3.5	2.0	MNX 18	MNX 50	MNX 50	REO 1.1	0.6	3	DN0-100M	32
5	3	2.2	4.9	2.8	MNX 18	MNX 50	MNX 50	REO 1.1	2.4	12	DN0-100M	32
6	4	3	6	3.5	MNX 18	MNX 50	MNX 50	REO 1.1	2.4	12	DN0-100M	32
7	5	3.7	7.5	4.3	MNX 18	MNX 50	MNX 50	REO 1.1	2.4	12	DN0-100M	32
8	5.5	4	8.5	4.9	MNX 18	MNX 50	MNX 50	REO 1.1	2.4	12	DN0-100M	32
9	7.5	5.5	11	6.4	MNX 18	MNX 50	MNX 50	REO 1.1	2.4	12	DN0-100M	32
10	10	7.5	14.5	8.4	MNX 18	MNX 50	MNX 50	REO 1.1	2.4	12	DN0-100M	40
11	12.5	9.3	17.3	10.0	MNX 25	MNX 50	MNX 50	REO 1.1	2.4	12	DN0-100M	40
12	15	11	21	12.1	MNX 25	MNX 50	MNX 50	REO 1.1	9	45	DN0-100M	50
13	17.5	13	24	13.9	MNX 25	MNX 50	MNX 50	REO 1.1	9	45	DN0-100M	63
14	20	15	29	16.7	MNX 25	MNX 80	MNX 80	REO 1.1	9	45	DN0-100M	80
15	25	18.5	35	20.2	MNX 50	MNX 80	MNX 80	REO 1.1	9	45	DN0-100M	80
16	30	22	40	23.1	MNX 50	MNX 80	MNX 80	REO 1.1	9	45	DN0-100M	100
17	40	30	54	31.2	MNX 50	MNX 95	MNX 95	REO 1.1	9	45	DN1-160M	125
18	50	37	68	39.3	MNX 50	MNX 95	MNX 95	REO 1.1	9	45	DN1-160M	160
19	60	45	81	46.8	MNX 70	MNX 95	MNX 95	REO 4	18	90	DN2-250M	200
20	75	55	94	54.3	MNX 70	MNX 95	MNX 95	REO 4	18	90	DN2-250M	200
21	100	75	130	75.1	MNX 80	MNX 250	MNX 250	REO 4	18	90	DN3-400M	320
22	110	80	139	80.3	MNX 95	MNX 250	MNX 250	REO 4	18	90	DN3-400M	320
23	120	90	157	90.6	MNX 95	MNX 250	MNX 250	REO 4	72	360	DN3-400M	320
24	150	110	189	109	MNX 110	MNX 250	MNX 250	REO 4	72	360	DN3-400M	400
25	170	125	207	120	MNX 140	MNX 300	MNX 300	REO 4	72	360	DN3-630M	500
26	180	132	226	131	MNX 140	MNX 300	MNX 300	REO 4	72	360	DN3-630M	500
27	200	150	248	143	MNX 185	MNX 300	MNX 300	REO 4	72	360	DN3-630M	500
28	215	160	270	156	MNX 185	MNX 300	MNX 300	REO 4	72	360	DN3-630M	630
29	240	180	298	172	MNX 185	MNX 300	MNX 300	REO 4	72	360	DN3-630M	630
30	270	200	336	194	MNX 650	MNX 650	MNX 650	REO 4	72	360	DN4-1250S (MTX 1.0 MCCB)	1250
31	300	225	360	207.9	MNX 650	MNX 650	MNX 650	REO 4	72	360	DN4-1250S (MTX 1.0 MCCB)	1250
32	335	250	420	242.5	MNX 650	MNX 650	MNX 650	REO 4	72	360	DN4-1250S (MTX 1.0 MCCB)	1250
33	370	275	440	254	MNX 650	MNX 650	MNX 650	REO 4	72	360	DN4-1250S (MTX 1.0 MCCB)	1250

Separate mounting kit required for REO 1.1

## Fuseless Protection for Star Delta Starter Feeders : IE3 Motors

TYPE '2' Co-ordination, Iq=50 kA at 415V, 3Ø, 50 Hz as per IS/IEC 60947-4-1 standard

SCPD Type	Contactor Type	Relay Type
DN MCCB	MO	RTO
		

Sr. No.	Motor Ratings at 3Ø, 415V, 50 Hz				Contactor Type			Overload Relay			MCCB	
	hp	kW	Current, In (A)		Star	Delta	Main	Type	Range (A)		Type	Rating (In)
			Line	Phase								
1	1	0.75	2	1.2	MO 18	MO 50	MO 50	REO 1.1	0.6	3	DN0-100M	32
2	1.5	1.1	2.7	1.6	MO 18	MO 50	MO 50	REO 1.1	0.6	3	DN0-100M	32
3	1.75	1.3	3	1.7	MO 18	MO 50	MO 50	REO 1.1	0.6	3	DN0-100M	32
4	2	1.5	3.5	2.0	MO 18	MO 50	MO 50	REO 1.1	0.6	3	DN0-100M	32
5	3	2.2	4.9	2.8	MO 18	MO 50	MO 50	REO 1.1	2.4	12	DN0-100M	32
6	4	3	6	3.5	MO 18	MO 50	MO 50	REO 1.1	2.4	12	DN0-100M	32
7	5	3.7	7.5	4.3	MO 18	MO 50	MO 50	REO 1.1	2.4	12	DN0-100M	32
8	5.5	4	8.5	4.9	MO 18	MO 50	MO 50	REO 1.1	2.4	12	DN0-100M	32
9	7.5	5.5	11	6.4	MO 18	MO 50	MO 50	REO 1.1	2.4	12	DN0-100M	32
10	10	7.5	14.5	8.4	MO 18	MO 50	MO 50	REO 1.1	2.4	12	DN0-100M	32
11	12.5	9.3	17.3	10.0	MO 25	MO 50	MO 50	RTO-2	6.7	9.7	DN0-100M	40
12	15	11	21	12.1	MO 25	MO 50	MO 50	RTO-2	10.5	16	DN0-100M	50
13	17.5	13	24	13.9	MO 25	MO 70	MO 70	RTO-2	10.5	16	DN0-100M	63
14	20	15	29	16.7	MO 25	MO 70	MO 70	RTO-2	15	21	DN0-100M	80
15	25	18.5	35	20.2	MO 50	MO 70	MO 70	RTO-2	15	21	DN0-100M	80
16	30	22	40	23.1	MO 50	MO 70	MO 70	RTO-2	20	31	DN0-100M	100
17	40	30	54	31.2	MO 50	MO 95	MO 95	RTO-3	29	38	DN1-160M	125
18	50	37	68	39.3	MO 50	MO 95	MO 95	RTO-3	37	49	DN1-160M	160
19	60	45	81	46.8	MO 70	MO 95	MO 95	RTO-3	37	49	DN2-250M	200
20	75	55	94	54.3	MO 70	MO 95	MO 95	RTO-3	47	62	DN2-250M	200
21	100	75	130	75.1	MO 80	MO 250	MO 250	RTO-4	57	84	DN3-400M	320
22	110	80	139	80.3	MO 95	MO 250	MO 250	RTO-4	57	84	DN3-400M	320
23	120	90	157	90.6	MO 95	MO 250	MO 250	RTO-4	72	108	DN3-400M	320
24	150	110	189	109	MO 110	MO 250	MO 250	RTO-4	105	156	DN3-400M	400
25	170	125	207	120	MO 140	MO 300	MO 300	RTO-4	105	156	DN3-630M	500
26	180	132	226	131	MO 140	MO 300	MO 300	RTO-4	105	156	DN3-630M	500
27	200	150	248	143	MO 185	MO 300	MO 300	RTO-4	105	156	DN3-630M	500

Separate mounting kit required for REO 1.1

## Fuseless Protection for Star Delta Starter Feeders : IE3 Motors

TYPE '2' Co-ordination, Iq=50 kA at 415V, 3Ø, 50 Hz as per IS/IEC 60947-4-1 standard



SCPD Type	Contactor Type	Relay Type
DN MCCB	MO	REO
		

Sr. No.	Motor Ratings at 3Ø, 415V, 50 Hz				Contactor Type			Overload Relay			MCCB	
	hp	kW	Current, In (A)		Star	Delta	Main	Type	Range (A)		Type	Rating (In)
			Line	Phase								
1	1	0.75	2	1.2	MO 18	MO 50	MO 50	REO 1.1	0.6	3	DN0-100M	32
2	1.5	1.1	2.7	1.6	MO 18	MO 50	MO 50	REO 1.1	0.6	3	DN0-100M	32
3	1.75	1.3	3	1.7	MO 18	MO 50	MO 50	REO 1.1	0.6	3	DN0-100M	32
4	2	1.5	3.5	2.0	MO 18	MO 50	MO 50	REO 1.1	0.6	3	DN0-100M	32
5	3	2.2	4.9	2.8	MO 18	MO 50	MO 50	REO 1.1	2.4	12	DN0-100M	32
6	4	3	6	3.5	MO 18	MO 50	MO 50	REO 1.1	2.4	12	DN0-100M	32
7	5	3.7	7.5	4.3	MO 18	MO 50	MO 50	REO 1.1	2.4	12	DN0-100M	32
8	5.5	4	8.5	4.9	MO 18	MO 50	MO 50	REO 1.1	2.4	12	DN0-100M	32
9	7.5	5.5	11	6.4	MO 18	MO 50	MO 50	REO 1.1	2.4	12	DN0-100M	32
10	10	7.5	14.5	8.4	MO 18	MO 50	MO 50	REO 1.1	2.4	12	DN0-100M	32
11	12.5	9.3	17.3	10.0	MO 25	MO 50	MO 50	REO 1.1	2.4	12	DN0-100M	40
12	15	11	21	12.1	MO 25	MO 50	MO 50	REO 1.1	9	45	DN0-100M	50
13	17.5	13	24	13.9	MO 25	MO 70	MO 70	REO 1.1	9	45	DN0-100M	63
14	20	15	29	16.7	MO 25	MO 70	MO 70	REO 1.1	9	45	DN0-100M	80
15	25	18.5	35	20.2	MO 50	MO 70	MO 70	REO 1.1	9	45	DN0-100M	80
16	30	22	40	23.1	MO 50	MO 70	MO 70	REO 1.1	9	45	DN0-100M	100
17	40	30	54	31.2	MO 50	MO 95	MO 95	REO 1.1	9	45	DN1-160M	125
18	50	37	68	39.3	MO 50	MO 95	MO 95	REO 1.1	9	45	DN1-160M	160
19	60	45	81	46.8	MO 70	MO 95	MO 95	REO 4	18	90	DN2-250M	200
20	75	55	94	54.3	MO 70	MO 95	MO 95	REO 4	18	90	DN2-250M	200
21	100	75	130	75.1	MO 80	MO 250	MO 250	REO 4	18	90	DN3-400M	320
22	110	80	139	80.3	MO 95	MO 250	MO 250	REO 4	18	90	DN3-400M	320
23	120	90	157	90.6	MO 95	MO 250	MO 250	REO 4	72	360	DN3-400M	320
24	150	110	189	109	MO 110	MO 250	MO 250	REO 4	72	360	DN3-400M	400
25	170	125	207	120	MO 140	MO 300	MO 300	REO 4	72	360	DN3-630M	500
26	180	132	226	131	MO 140	MO 300	MO 300	REO 4	72	360	DN3-630M	500
27	200	150	248	143	MO 185	MO 300	MO 300	REO 4	72	360	DN3-630M	500

Separate mounting kit required for REO 1.1

## Fuseless Protection for Star Delta Starter Feeders : IE3 Motors

TYPE '2' Co-ordination, Iq=50 kA at 415V, 3Ø, 50 Hz as per IS/IEC 60947-4-1 standard

SCPD Type	Contactor Type	Relay Type
MOG MPCB	MNX	MN
		

Sr. No.	Ratings at 3Ø, 415V, 50 Hz				Contactor Type			Overload Relay		MPCB	
	hp	kW	Current, In (A)		Star	Delta	Main	Type	Range (A)	Type	Rating (A)
			Line	Phase							
1	0.33	0.25	0.8	0.5	MNX 9	MNX 9	MNX 9	MN2	0.45 - 0.75	MOG-H1M	1.6
2	0.5	0.37	1.2	0.7	MNX 9	MNX 9	MNX 9	MN2	0.6 - 1	MOG-H1M	2.5
3	0.75	0.55	1.5	0.9	MNX 9	MNX 9	MNX 9	MN2	0.9 - 1.5	MOG-H1M	2.5
4	1	0.75	2.0	1.2	MNX 9	MNX 18	MNX 18	MN2	0.9 - 1.5	MOG-H1M	4.0
5	1.5	1.1	2.7	1.6	MNX 9	MNX 22	MNX 22	MN2	1.4 - 2.3	MOG-H1M	6.3
6	1.75	1.3	3.0	1.7	MNX 9	MNX 22	MNX 22	MN2	1.4 - 2.3	MOG-H1M	6.3
7	2	1.5	3.5	2.0	MNX 9	MNX 22	MNX 22	MN2	2.0 - 3.3	MOG-H1M	6.3
8	3	2.2	4.9	2.8	MNX 9	MNX 25	MNX 25	MN2	2.0 - 3.3	MOG-H1M	10.0
9	4	3	6.0	3.5	MNX 9	MNX 25	MNX 25	MN2	3.0 - 5.0	MOG-H1M	10.0
10	5	3.7	7.5	4.3	MNX 9	MNX 25	MNX 25	MN2	3.0 - 5.0	MOG-H1M	16.0
11	5.5	4	8.5	4.9	MNX 9	MNX 25	MNX 25	MN2	4.5 - 7.5	MOG-H1M	16.0
12	7.5	5.5	11.0	6.4	MNX 9	MNX 32	MNX 32	MN2	6 - 10	MOG-H1M	20.0
13	10	7.5	14.5	8.4	MNX 18	MNX 40	MNX 40	MN2	6 - 10	MOG-H1M	25.0
14	12.5	9.3	17.3	10.0	MNX 18	MNX 50	MNX 50	MN5	9 - 15	MOG-H1M	32.0
15	15	11	21.0	12.1	MNX 18	MNX 50	MNX 50	MN5	9 - 15	MOG-H1M	32.0
16	17.5	13	24.0	13.9	MNX 18	MNX 70	MNX 70	MN5	14 - 23	MOG-H2M	40.0
17	20	15	29.0	16.7	MNX 25	MNX 70	MNX 70	MN5	14 - 23	MOG-H2M	50.0
18	25	18.5	35.0	20.2	MNX 25	MNX 80	MNX 80	MN5	20 - 33	MOG-H2M	63.0
19	30	22	40.0	23.1	MNX 32	MNX 80	MNX 80	MN5	20 - 33	MOG-H2M	63.0

## Fuseless Protection for Star Delta Starter Feeders : IE3 Motors

TYPE '2' Co-ordination, Iq=50 kA at 415V, 3Ø, 50 Hz as per IS/IEC 60947-4-1 standard

SCPD Type	Contactor Type	Relay Type
MOG MPCB	MNX	REO
		

Sr. No.	Ratings at 3Ø, 415V, 50 Hz				Contactor Type			Overload Relay		MPCB	
	hp	kW	Current, In (A)		Star	Delta	Main	Type	Range (A)	Type	Rating (A)
			Line	Phase							
1	0.33	0.25	0.8	0.5	MNX 9	MNX 9	MNX 9	REO 1.1	0.15 - 0.75	MOG-H1M	1.6
2	0.5	0.37	1.2	0.7	MNX 9	MNX 9	MNX 9	REO 1.1	0.6 - 3	MOG-H1M	2.5
3	0.75	0.55	1.5	0.9	MNX 9	MNX 9	MNX 9	REO 1.1	0.6 - 3	MOG-H1M	2.5
4	1	0.75	2.0	1.2	MNX 9	MNX 18	MNX 18	REO 1.1	0.6 - 3	MOG-H1M	4.0
5	1.5	1.1	2.7	1.6	MNX 9	MNX 22	MNX 22	REO 1.1	0.6 - 3	MOG-H1M	6.3
6	1.75	1.3	3.0	1.7	MNX 9	MNX 22	MNX 22	REO 1.1	0.6 - 3	MOG-H1M	6.3
7	2	1.5	3.5	2.0	MNX 9	MNX 22	MNX 22	REO 1.1	0.6 - 3	MOG-H1M	6.3
8	3	2.2	4.9	2.8	MNX 9	MNX 25	MNX 25	REO 1.1	2.4 - 12	MOG-H1M	10.0
9	4	3	6.0	3.5	MNX 9	MNX 25	MNX 25	REO 1.1	2.4 - 12	MOG-H1M	10.0
10	5	3.7	7.5	4.3	MNX 9	MNX 25	MNX 25	REO 1.1	2.4 - 12	MOG-H1M	16.0
11	5.5	4	8.5	4.9	MNX 9	MNX 25	MNX 25	REO 1.1	2.4 - 12	MOG-H1M	16.0
12	7.5	5.5	11.0	6.4	MNX 9	MNX 32	MNX 32	REO 1.1	2.4 - 12	MOG-H1M	20.0
13	10	7.5	14.5	8.4	MNX 18	MNX 40	MNX 40	REO 1.1	2.4 - 12	MOG-H1M	25.0
14	12.5	9.3	17.3	10.0	MNX 18	MNX 50	MNX 50	REO 1.1	2.4 - 12	MOG-H1M	32.0
15	15	11	21.0	12.1	MNX 18	MNX 50	MNX 50	REO 1.1	9 - 45	MOG-H1M	32.0
16	17.5	13	24.0	13.9	MNX 18	MNX 70	MNX 70	REO 1.1	9 - 45	MOG-H2M	40.0
17	20	15	29.0	16.7	MNX 25	MNX 70	MNX 70	REO 1.1	9 - 45	MOG-H2M	50.0
18	25	18.5	35.0	20.2	MNX 25	MNX 80	MNX 80	REO 1.1	9 - 45	MOG-H2M	63.0
19	30	22	40.0	23.1	MNX 32	MNX 80	MNX 80	REO 1.1	9 - 45	MOG-H2M	63.0

Separate mounting kit required



## Fuseless Protection for Star Delta Starter Feeders : IE3 Motors

TYPE '2' Co-ordination, I<sub>q</sub>=50 kA at 415V, 3Ø, 50 Hz as per IS/IEC 60947-4-1 standard

SCPD Type	Contactors Type	Relay Type
MOG MPCB	MO	RTO
		

Sr. No.	Motor Ratings at 3Ø, 415V, 50 Hz				Contactors Type			Overload Relay		MPCB	
	hp	kW	I line (A)	I phase (A)	Star	Delta	Main	Type	Range (A)	Type	Rating (A)
1	0.33	0.25	0.8	0.5	MO 9	MO 9	MO 9	RTO1	0.31 - 0.55	MOG-H1M	1.6
2	0.5	0.37	1.2	0.7	MO 9	MO 9	MO 9	RTO1	0.55 - 0.85	MOG-H1M	2.5
3	0.75	0.55	1.5	0.9	MO 9	MO 9	MO 9	RTO1	0.78 - 1.2	MOG-H1M	2.5
4	1	0.75	2.0	1.2	MO 9	MO 12	MO 12	RTO1	1.2 - 2	MOG-H1M	4
5	1.5	1.1	2.7	1.6	MO 9	MO 18	MO 18	RTO1	1.2 - 2	MOG-H1M	6.3
6	1.75	1.3	3.0	1.7	MO 9	MO 18	MO 18	RTO1	1.2 - 2	MOG-H1M	6.3
7	2	1.5	3.5	2.0	MO 9	MO 18	MO 18	RTO1	1.9 - 2.8	MOG-H1M	6.3
8	3	2.2	4.9	2.8	MO 9	MO 25	MO 25	RTO1	2.4 - 3.6	MOG-H1M	10
9	4	3	6.0	3.5	MO 9	MO 25	MO 25	RTO1	2.4 - 3.6	MOG-H1M	10
10	5	3.7	7.5	4.3	MO 9	MO 25	MO 25	RTO1	3.5 - 5.2	MOG-H1M	16
11	5.5	4	8.5	4.9	MO 9	MO 25	MO 25	RTO1	3.5 - 5.2	MOG-H1M	16
12	7.5	5.5	11.0	6.4	MO 9	MO 32	MO 32	RTO1	4.6 - 6.7	MOG-H1M	20
13	10	7.5	14.5	8.4	MO 18	MO 32	MO 32	RTO1	6.7 - 9.7	MOG-H1M	25
14	12.5	9.3	17.3	10.0	MO 18	MO 45	MO 45	RTO1	8.5 - 12.5	MOG-H1M	32
15	15	11	21.0	12.1	MO 18	MO 50	MO 50	RTO2	10.5 - 16	MOG-H1M	32
16	17.5	13	24.0	13.9	MO 18	MO 50	MO 50	RTO2	10.5 - 16	MOG-H2M	40
17	20	15	29.0	16.7	MO 25	MO 60	MO 60	RTO2	15 - 21	MOG-H2M	50
18	25	18.5	35.0	20.2	MO 25	MO 70	MO 70	RTO2	15 -21	MOG-H2M	63
19	30	22	40.0	23.1	MO 32	MO 70	MO 70	RTO2	20 - 31	MOG-H2M	63

## Fuseless Protection for Star Delta Starter Feeders : IE3 Motors

TYPE '2' Co-ordination, I<sub>q</sub>=50 kA at 415V, 3Ø, 50 Hz as per IS/IEC 60947-4-1 standard

SCPD Type	Contactor Type	Relay Type
MOG MPCB	MO	REO
		

Sr. No.	Motor Ratings at 3Ø, 415V, 50 Hz				Contactor Type			Overload Relay		MPCB	
	hp	kW	I line (A)	I phase (A)	Star	Delta	Main	Type	Range (A)	Type	Rating (A)
1	0.33	0.25	0.8	0.5	MO 9	MO 9	MO 9	REO 1.1	0.15 - 0.75	MOG-H1M	1.6
2	0.5	0.37	1.2	0.7	MO 9	MO 9	MO 9	REO 1.1	0.6 - 3	MOG-H1M	2.5
3	0.75	0.55	1.5	0.9	MO 9	MO 9	MO 9	REO 1.1	0.6 - 3	MOG-H1M	2.5
4	1	0.75	2.0	1.2	MO 9	MO 12	MO 12	REO 1.1	0.6 - 3	MOG-H1M	4
5	1.5	1.1	2.7	1.6	MO 9	MO 18	MO 18	REO 1.1	0.6 - 3	MOG-H1M	6.3
6	1.75	1.3	3.0	1.7	MO 9	MO 18	MO 18	REO 1.1	0.6 - 3	MOG-H1M	6.3
7	2	1.5	3.5	2.0	MO 9	MO 18	MO 18	REO 1.1	0.6 - 3	MOG-H1M	6.3
8	3	2.2	4.9	2.8	MO 9	MO 25	MO 25	REO 1.1	2.4 - 12	MOG-H1M	10
9	4	3	6.0	3.5	MO 9	MO 25	MO 25	REO 1.1	2.4 - 12	MOG-H1M	10
10	5	3.7	7.5	4.3	MO 9	MO 25	MO 25	REO 1.1	2.4 - 12	MOG-H1M	16
11	5.5	4	8.5	4.9	MO 9	MO 25	MO 25	REO 1.1	2.4 - 12	MOG-H1M	16
12	7.5	5.5	11.0	6.4	MO 9	MO 32	MO 32	REO 1.1	2.4 - 12	MOG-H1M	20
13	10	7.5	14.5	8.4	MO 18	MO 32	MO 32	REO 1.1	2.4 - 12	MOG-H1M	25
14	12.5	9.3	17.3	10.0	MO 18	MO 45	MO 45	REO 1.1	2.4 - 12	MOG-H1M	32
15	15	11	21.0	12.1	MO 18	MO 50	MO 50	REO 1.1*	9 - 45	MOG-H1M	32
16	17.5	13	24.0	13.9	MO 18	MO 50	MO 50	REO 1.1*	9 - 45	MOG-H2M	40
17	20	15	29.0	16.7	MO 25	MO 60	MO 60	REO 1.1*	9 - 45	MOG-H2M	50
18	25	18.5	35.0	20.2	MO 25	MO 70	MO 70	REO 1.1*	9 - 45	MOG-H2M	63
19	30	22	40.0	23.1	MO 32	MO 70	MO 70	REO 1.1*	9 - 45	MOG-H2M	63

\* Separate mounting kit required

SCPD Type	Contactor Type	Relay Type
DZ MCCB	MO	RTO
		

NEW

### Fuseless Protection for DOL Starter Feeders : IE2 Motors

TYPE '2' Co-ordination, I<sub>q</sub>=50 kA at 415V, 3Ø, 50 Hz as per IS/IEC 60947-4-1 standard

Motor Ratings at 3Ø, 415V, 50 Hz			Contactor		Overload Relay		MCCB	
hp	kW	FLC In (A)	Type	Type	Range (A)		Type	Rating (A)
50	37	68	MO 80	RTO-3	60	78	DZ1-160N (FM)	100
60	45	81	MO 95	RTO-4	72	108	DZ1-160N (FM)	100
75	55	94	MO 140	RTO-4	72	108	DZ1-160N (FM)	125

### Fuseless Protection for Star Delta Starter Feeders : IE2 Motors

TYPE '2' Co-ordination, I<sub>q</sub>=50 kA at 415V, 3Ø, 50 Hz as per IS/IEC 60947-4-1 standard

Motor Ratings at 3Ø, 415V, 50 Hz				Contactor			Overload Relay			MCCB	
hp	kW	Current In (A)		Star	Delta	Main	Type	Range (A)	Type	Rating (A)	
		FLC In (A)	I <sub>ph</sub> (A)								
50	37	68	39.3	MO 40	MO 95	MO 95	RTO-3	37	49	DZ1-160N (FM)	100

### Fuseless Protection for DOL Starter Feeders : IE3 Motors

TYPE '2' Co-ordination, I<sub>q</sub>=50 kA at 415V, 3Ø, 50 Hz as per IS/IEC 60947-4-1 standard

Motor Ratings at 3Ø, 415V, 50 Hz			Contactor		Overload Relay		MCCB	
hp	kW	FLC In (A)	Type	Type	Range (A)		Type	Rating (A)
50	37	68	MO 80	RTO-3	60	78	DZ1-160N (FM)	100
60	45	81	MO 140	RTO-4	72	108	DZ1-160N (FM)	125
75	55	94	MO 185	RTO-4	72	108	DZ1-160N (FM)	160

### Fuseless Protection for Star Delta Starter Feeders : IE3 Motors

TYPE '2' Co-ordination, I<sub>q</sub>=50 kA at 415V, 3Ø, 50 Hz as per IS/IEC 60947-4-1 standard

Motor Ratings at 3Ø, 415V, 50 Hz				Contactor			Overload Relay			MCCB	
hp	kW	Current In (A)		Star	Delta	Main	Type	Range (A)	Type	Rating (A)	
		FLC In (A)	I <sub>ph</sub> (A)								
40	30	54	31.2	MO 40	MO 80	MO 80	REO	9	45	DZ1-160N (FM)	100
50	37	68	39.3	MO 40	MO 95	MO 95	RTO-3	37	49	DZ1-160N (FM)	125

# Get the Switchgear Training Edge!

Aimed at maximizing productivity, conserving energy, minimizing costs and enhancing safety, our Electrical & Automation training programmes have benefitted over 1.77 Lakh professionals in the last 30 years. These training programmes are highly beneficial as they provide right exposure and impart knowledge on selection, installation, maintenance and testing of Electrical & Automation Products.

## So gain the advantage and go the extra mile with:

- 14 courses on contemporary topics
- Courses applicable to all switchgear brands
- Training Centers in Pune, Lucknow, Coonoor, Vadodara, Delhi & Kolkata
- Blend of theory and practical experience

## The typical training programmes cover:

- Low Voltage & Medium Voltage Switchgear
- Switchboard Electrical Design
- AC Drives & Building Management Solutions
- Protective Relays & Earthing
- Power Quality Solutions

Please contact any of the training centres for participation and detailed training programme schedule.



### Pune

L&T Electrical & Automation  
Switchgear Training Centre  
T-156 / 157, MIDC,  
Bhosari, Pune - 411 026  
Tel: 020 2712 0037 / 2712 0653  
E-mail: stc-pune@Lntebg.com



### Lucknow

L&T Electrical & Automation  
Switchgear Training Centre  
C-6 & 7, UPSIDC,  
P. O. Sarojininagar,  
Lucknow - 226 008  
Tel: 0522 247 6015 / 97944 54455  
E-mail: stc-lucknow@Lntebg.com



### Delhi

L&T Electrical & Automation  
Switchgear Training Centre  
A-25, Imperia Complex, First Floor  
Mohan Cooperative Industrial Estate  
Near Sarita Vihar / Mohan Estate Metro Station  
Main Mathura Road, New Delhi - 110044  
Tel: 9899020306, 9720186726, 9560845094  
E-mail: stc-delhi@Lntebg.com



### Coonoor

L&T Electrical & Automation  
Switchgear Training Centre  
Ooty-Coonoor Main Road  
Yellanahalli P.O.,  
The Nilgiris - 643 243  
Tel. : 0423 251 7107  
E-mail: stc-coonoor@Lntebg.com



### Vadodara

L&T Electrical & Automation  
Switchgear Training Centre  
Behind L&T Knowledge City,  
Near Village Ankhol,  
Vadodara - 390019  
Tel: 0265 6147805 / 6147808  
E-mail: stc-vadodara@Lntebg.com



### Kolkata

L&T Electrical & Automation,  
Switchgear Training Centre,  
2nd Floor, Block BN3, Sector V,  
Salt Lake City,  
Kolkata - 700091, West Bengal  
Contact No. : 9051580700 / 9874448612  
E-mail: stc-kolkata@Lntebg.com

## Electrical Standard Products (ESP) Offices:

### HEAD OFFICE

L&T Electrical & Automation  
TC-II, Tower B, Prima Bay,  
Gate No. 5, Saki Vihar Road, Powai,  
**MUMBAI - 400072.**  
Tel: 022-67052874 / 2737 / 1156  
e-mail: cic@Lntebg.com

### BRANCH OFFICES

L&T Electrical & Automation  
C-201, The First Commercial Complex,  
B/S Keshavbaug Party Plot, Vastrapur,  
**Ahmedabad - 380015**  
Toll Free: 1800 233 5858 / 1800 200 5858  
e-mail: CIC@Lntebg.com

L&T Electrical & Automation  
Wework Central, #36 Infantry Road,  
**Bengaluru - 560 001**  
Toll Free: 1800 233 5858 / 1800 200 5858  
e-mail: CIC@Lntebg.com

L&T Electrical & Automation  
Under O Launchpad, 4th floor,  
Unit-434, Esplanade 1, Rasulgarh,  
**Bhubaneswar - 751010**  
Toll Free: 1800 233 5858 / 1800 200 5858  
e-mail: CIC@Lntebg.com

L&T Electrical & Automation  
4th floor, SCO-54,55,56,  
Sector -17A  
**Chandigarh - 160017**  
Toll Free: 1800 233 5858 / 1800 200 5858  
e-mail: CIC@Lntebg.com

L&T Electrical & Automation  
Olympia Technology Park,  
10th Floor, CITIUS A Block,  
Plot No. 1, Phase 1, Guindy,  
**Chennai - 600032**  
Toll Free: 1800 233 5858 / 1800 200 5858  
e-mail: CIC@Lntebg.com

L&T Electrical & Automation  
Playworkz Coworking Space  
43 & 44, 3rd Cross,  
Bharathy Colony, Peelamedu,  
**Coimbatore - 641004**  
Toll Free: 1800 233 5858 / 1800 200 5858  
e-mail: CIC@Lntebg.com

L&T Electrical & Automation  
3rd Floor, 1&2 Vijay Park,  
Main Chakrata Road, Opp. Anandam  
Near Ballapur chowk,  
**Dehradun - 248001**  
Toll Free: 1800 233 5858 / 1800 200 5858  
e-mail: CIC@Lntebg.com

L&T Electrical & Automation  
Ground Floor, B-27, Biplab Rashbihari Sarani,  
Sector 2A, Bidhan Nagar,  
**Durgapur - 713212**  
Toll Free: 1800 233 5858 / 1800 200 5858  
e-mail: CIC@Lntebg.com

L&T Electrical & Automation  
6th floor, Exotica Greens, A Block, 191,  
R G Baruah Road, Guwahati Central,  
**Guwahati - 781005**  
Toll Free: 1800 233 5858 / 1800 200 5858  
e-mail: CIC@Lntebg.com

L&T Electrical & Automation  
Shri Daneshwari, 1st Floor,  
Plot No. 17, 2nd Cross,  
Near Old Income Tax Office Road,  
Vidyanagar,  
**Hubballi - 580021**  
Toll Free: 1800 233 5858 / 1800 200 5858  
e-mail: CIC@Lntebg.com

L&T Electrical & Automation  
AWFIS space solutions, Prestige Phoenix,  
4th floor, 1405, Umanagar, Begumpet,  
**Hyderabad - 500016**  
Toll Free: 1800 233 5858 / 1800 200 5858  
e-mail: CIC@Lntebg.com

L&T Electrical & Automation  
Workie, 214 - 2nd Floor,  
Apollo Premier, PU-4,  
Scheme No. 54,  
Vijay Nagar Square,  
**Indore - 452010**  
Toll Free: 1800 233 5858 / 1800 200 5858  
e-mail: CIC@Lntebg.com

L&T Electrical & Automation  
Office No 430, 4th floor,  
Jaipur Electronic Market  
Riddhi Siddhi,  
Gopalpura Bypass,  
**Jaipur - 302018**  
Toll Free: 1800 233 5858 / 1800 200 5858  
e-mail: CIC@Lntebg.com

L&T Electrical & Automation  
GDR Siddha, Ground Floor, N Road  
Bistupur, Opposite St. Mary's Church,  
**Jamshedpur - 831001**  
Toll Free: 1800 233 5858 / 1800 200 5858  
e-mail: CIC@Lntebg.com

L&T Electrical & Automation  
Business Communication Centre  
2nd Floor, Chiramel Chambers,  
Kurisupally Road,  
Ravipuram,  
**Kochi - 682 015**  
Toll Free: 1800 233 5858 / 1800 200 5858  
e-mail: CIC@Lntebg.com

L&T Electrical & Automation  
2nd Floor, BN3, Salt Lake, Sector-V,  
**Kolkata - 700091**  
Toll Free: 1800 233 5858 / 1800 200 5858  
e-mail: CIC@Lntebg.com

L&T Electrical & Automation  
No. 10, Fortuna Towers, 2nd floor,  
Rana Pratap Marg, Near NBRI  
**Lucknow - 226001**  
Toll Free: 1800 233 5858 / 1800 200 5858  
e-mail: CIC@Lntebg.com

L&T Electrical & Automation  
El Dorado Building 3rd Floor,  
6, Venkatraman Street,  
Chinna Chokkikulam  
**Madurai - 625 002**  
Toll Free: 1800 233 5858 / 1800 200 5858  
e-mail: CIC@Lntebg.com

L&T Electrical & Automation  
TC II, Tower B, PRIMA BAY  
Gate no. 5, Saki Vihar Road Powai,  
**Mumbai - 400072**  
Toll Free: 1800 233 5858 / 1800 200 5858  
e-mail: CIC@Lntebg.com

L&T Electrical & Automation  
Unnati Building, 2nd floor,  
Automation Campus, A-600, TTC Industrial area  
Shil-Mahape road, Mahape  
**Navi Mumbai - 400710**  
Toll Free: 1800 233 5858 / 1800 200 5858  
e-mail: CIC@Lntebg.com

L&T Electrical & Automation  
M1 & M2, Mezzanine Floor,  
Himalaya Excellency, Plot No.-C - 47,  
Pratap Nagar Square,  
**Nagpur - 440022**  
Toll Free: 1800 233 5858 / 1800 200 5858  
e-mail: CIC@Lntebg.com

L&T Electrical & Automation  
A-25, 1st Floor, Imperia Complex,  
Mohan Corporative Industrial Estate,  
Near Sarita Vihar Metro Station,  
Mathura Road,  
**New Delhi - 110044**  
Toll Free: 1800 233 5858 / 1800 200 5858  
e-mail: CIC@Lntebg.com

L&T Electrical & Automation  
A06/A07, Second Floor,  
Grand Chandra complex, Frazer road  
**Patna - 800001**  
Toll Free: 1800 233 5858 / 1800 200 5858  
e-mail: CIC@Lntebg.com

L&T Electrical & Automation  
UrbanWrk, 5th Floor, Sai Radhe,  
Raja Bahadur Mill road, Behind Hotel  
Grand Sheraton, Sangamwadi  
**Pune - 411001**  
Toll Free: 1800 233 5858 / 1800 200 5858  
e-mail: CIC@Lntebg.com

L&T Electrical & Automation  
Unit No. 207, 2nd Floor, Wallfort Ozone,  
Raipur Road, Near Fafadih Chowk,  
**Raipur - 492001**  
Toll Free: 1800 233 5858 / 1800 200 5858  
e-mail: CIC@Lntebg.com

L&T Electrical & Automation  
10th Floor, Titaanium Business,  
Bhimrad Road, Althan  
**Surat - 395017**  
Toll Free: 1800 233 5858 / 1800 200 5858  
e-mail: CIC@Lntebg.com

L&T Electrical & Automation  
11th Floor, Block-D, Notus IT Park,  
Sarabhai Campus, Bhailal Amin Marg,  
**Vadodara - 390023**  
Toll Free: 1800 233 5858 / 1800 200 5858  
e-mail: CIC@Lntebg.com

L&T Electrical & Automation  
414, 4th Floor, Naga Chambers,  
Opposite HDFC Bank  
Ram Nagar, Waltair Main Road  
**Visakhapatnam - 530002**  
Toll Free: 1800 233 5858 / 1800 200 5858  
e-mail: CIC@Lntebg.com

Product improvement is a continuous process, For the latest information and special application, please contact any of our offices listed here.  
Product photographs shown for representative purpose only.



L&T Electrical & Automation, Electrical Standard Products  
TC-II, Tower B, Prima Bay, 3rd Floor, Gate No. 5, Saki Vihar Road, Powai,  
Mumbai - 400 072, INDIA. Web: www.Lntebg.com

Customer Interaction Centre (CIC)  
BSNL/MTNL (toll-free): 1800 233 5858 Reliance (toll-free): 1800 200 5858  
Tel: 022 6774 5858 Email:cic@Lntebg.com Web: www.Lntebg.com